

BA 251F/00/en/12.03  
Nr. 52012496  
Valid as of software version:  
V 01.02.00 (amplifier)  
V 01.02.00 (communication)

# *micropilot M* **FMR 245** **HART/4...20 mA** **Level-Radar**

## Operating Instructions

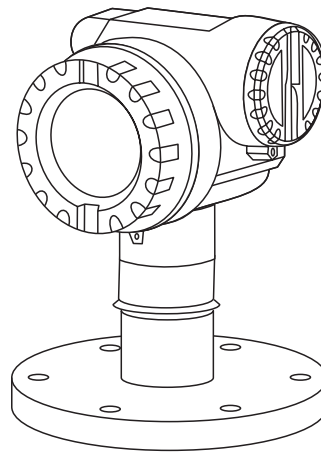

**Endress + Hauser**

The Power of Know How



# Brief operating instructions

KA 159F/00/a2/05.02  
52006292

## Micropilot M - Brief operating instructions

**Contrast:**  $E + +$  or  $E + -$

|  |  |   |  |                         |                         |                                 |                                       |   |                                     |                   |                      |
|--|--|---|--|-------------------------|-------------------------|---------------------------------|---------------------------------------|---|-------------------------------------|-------------------|----------------------|
| 000 measured value                       |  |   |  |                         |                         |                                 |                                       |   |                                     |                   | 008 dist./meas value |
| Group selection                          |  |   |  |                         |                         |                                 |                                       |   |                                     |                   |                      |
| 00 basic setup                           | 002 tank shape                                     | 003 medium cond.  | 004 process cond.                                      | 005 empty calibr.       | 006 full calibr.        | 007 pipe diameter               | 008 dist./meas value                  | 051 check distance  | 052 range of mapping                | 053 start mapping |                      |
| 01 safety settings                       | - dome ceiling<br>- horizontal cyl.<br>- bypass    | - unknown<br>- DC: <1.9<br>- DC: 1.9 ... 4<br>- DC: >10 | - standard<br>- calm surface<br>- add. agitator<br>... | input E<br>(see sketch) | input F<br>(see sketch) | only for bypass + stilling well | D and L are displayed<br>(see sketch) | - ok<br>- too small<br>- too big<br>- unknown<br>- manual | confirm suggestion or specify range |                   |                      |
| 04 linearisation                         |  |   |  |                         |                         |                                 |                                       |   |                                     |                   |                      |
| 05 extended calibr.                      |  |   |  |                         |                         |                                 |                                       |   |                                     |                   |                      |
| 06 output (HART, FF) profibus param.(PA) |  |   |  |                         |                         |                                 |                                       |   |                                     |                   |                      |
| 09 display                               | 092 language                                       |   |  |                         |                         |                                 |                                       |   |                                     |                   |                      |
| 0E envelope curve                        | 0E1 plot settings                                  | 0E2 recording curve                                     |  |                         |                         |                                 |                                       |   |                                     |                   |                      |
|  | - envel. curve<br>- incl. FAC<br>- incl. cust. map | - single curve<br>- cyclic                              |  |                         |                         |                                 |                                       |   |                                     |                   |                      |
| 0A diagnostics                           | 0A0 present error                                  | 0A1 previous error                                      | ...  | 0A4 unlock parameter    |                         |                                 |                                       |   |                                     |                   |                      |
| 0C system parameter                      |  |   |  |                         |                         |                                 |                                       |   |                                     |                   |                      |

threaded connection:  
reference point of measurement

flange:  
reference point of measurement

52006292

= 100: unlocked } HART  
 ≠ 100: locked }  
 = 2457: unlocked } PA, FF  
 ≠ 2457: locked }

L00-FMR2xxxx-19-00-00-en-039



**Note!**

This operating manual explains the installation and initial start-up for the level transmitter. All functions that are required for a typical measuring task are taken into account here. In addition, the Micropilot M provides many other functions that are not included in this operating manual, such as optimising the measuring point and converting the measured values.

An **overview of all device functions** can be found on Page 82.

The operating manual BA 221F/00/en "Description of the instrument functions for Micropilot M" provides an **extensive description of all device functions**, which can be found on the enclosed CD-ROM.

# Table of contents

|          |   |           |                    |  |           |
|----------|---|-----------|--------------------|--|-----------|
| <b>1</b> | <b>Safety instructions</b> .....              | <b>4</b>  | 9.7                | Disposal .....   | 77        |
| 1.1      | Designated use .....                          | 4         | 9.8                | Software history .....                                 | 77        |
| 1.2      | Installation, commissioning and operation ... | 4         | 9.9                | Contact addresses of Endress+Hauser .....              | 77        |
| 1.3      | Operational safety .....                      | 4         |                    |  |           |
| 1.4      | Notes on safety conventions and symbols ...   | 5         | <b>10</b>          | <b>Technical data</b> .....                            | <b>78</b> |
| <b>2</b> | <b>Identification</b> .....                   | <b>6</b>  | 10.1               | Additional technical data .....                        | 78        |
| 2.1      | Device designation .....                      | 6         | <b>11</b>          | <b>Appendix</b> .....                                  | <b>82</b> |
| 2.2      | Scope of delivery .....                       | 8         | 11.1               | Operating menu HART (display modul),<br>ToF Tool ..... | 82        |
| 2.3      | Certificates and approvals .....              | 8         | 11.2               | Operating matrix HART / Commuwin II .....              | 84        |
| 2.4      | Registered trademarks .....                   | 8         | 11.3               | Description of functions .....                         | 85        |
| <b>3</b> | <b>Mounting</b> .....                         | <b>9</b>  | 11.4               | Function and system design .....                       | 86        |
| 3.1      | Quick installation guide .....                | 9         |                    |  |           |
| 3.2      | Incoming acceptance, transport, storage ...   | 10        | <b>Index</b> ..... |  | <b>89</b> |
| 3.3      | Installation conditions .....                 | 11        |                    |  |           |
| 3.4      | Installation instructions .....               | 17        |                    |  |           |
| 3.5      | Post-installation check .....                 | 22        |                    |  |           |
| <b>4</b> | <b>Wiring</b> .....                           | <b>23</b> |                    |  |           |
| 4.1      | Quick wiring guide .....                      | 23        |                    |  |           |
| 4.2      | Connecting the measuring unit .....           | 25        |                    |  |           |
| 4.3      | Recommended connection .....                  | 28        |                    |  |           |
| 4.4      | Degree of protection .....                    | 28        |                    |  |           |
| 4.5      | Post-connection check .....                   | 28        |                    |  |           |
| <b>5</b> | <b>Operation</b> .....                        | <b>29</b> |                    |  |           |
| 5.1      | Quick operation guide .....                   | 29        |                    |  |           |
| 5.2      | Display and operating elements .....          | 31        |                    |  |           |
| 5.3      | Local operation .....                         | 33        |                    |  |           |
| 5.4      | Display and acknowledging error messages      | 36        |                    |  |           |
| 5.5      | HART communication .....                      | 37        |                    |  |           |
| <b>6</b> | <b>Commissioning</b> .....                    | <b>40</b> |                    |  |           |
| 6.1      | Function check .....                          | 40        |                    |  |           |
| 6.2      | Switching on the measuring device .....       | 40        |                    |  |           |
| 6.3      | Basic Setup .....                             | 41        |                    |  |           |
| 6.4      | Basic Setup with the VU 331 .....             | 43        |                    |  |           |
| 6.5      | Basic Setup with the ToF Tool .....           | 55        |                    |  |           |
| <b>7</b> | <b>Maintenance</b> .....                      | <b>60</b> |                    |  |           |
| <b>8</b> | <b>Accessories</b> .....                      | <b>61</b> |                    |  |           |
| <b>9</b> | <b>Trouble-shooting</b> .....                 | <b>63</b> |                    |  |           |
| 9.1      | Trouble-shooting instructions .....           | 63        |                    |  |           |
| 9.2      | System error messages .....                   | 64        |                    |  |           |
| 9.3      | Application errors .....                      | 66        |                    |  |           |
| 9.4      | Orientation of the Micropilot .....           | 68        |                    |  |           |
| 9.5      | Spare parts .....                             | 70        |                    |  |           |
| 9.6      | Return .....                                  | 77        |                    |  |           |

# 1 Safety instructions

## 1.1 Designated use

The Micropilot M FMR 245 is a compact radar level transmitter for the continuous, contactless measurement of liquids, pastes and sludge. The device can also be freely mounted outside closed metal vessels because of its operating frequency of about 26 GHz and a maximum radiated pulsed energy of 1mW (average power output 1  $\mu$ W). Operation is completely harmless to humans and animals.

## 1.2 Installation, commissioning and operation

The Micropilot M has been designed to operate safely in accordance with current technical, safety and EU standards. If installed incorrectly or used for applications for which it is not intended, however, it is possible that application-related dangers may arise, e.g. product overflow due to incorrect installation or calibration. For this reason, the instrument must be installed, connected, operated and maintained according to the instructions in this manual: personnel must be authorised and suitably qualified. The manual must have been read and understood, and the instructions followed. Modifications and repairs to the device are permissible only when they are expressly approved in the manual.

## 1.3 Operational safety

### 1.3.1 Hazardous areas

Measuring systems for use in hazardous environments are accompanied by separate "Ex documentation", which is an integral part of this Operating Manual. Strict compliance with the installation instructions and ratings as stated in this supplementary documentation is mandatory.

- Ensure that all personnel are suitably qualified.
- Observe the specifications in the certificate as well as national and local regulations.

### 1.3.2 FCC approval

This device complies with part 15 of the FCC Rules. Operation is subject to the following two conditions: (1) This device may not cause harmful interference, and (2) this device must accept any interference received, including interference that may cause undesired operation.









Caution!





Changes or modifications not expressly approved by the part responsible for compliance could void the user's authority to operate the equipment.

## 1.4 Notes on safety conventions and symbols

In order to highlight safety-relevant or alternative operating procedures in the manual, the following conventions have been used, each indicated by a corresponding symbol in the margin.

| Symbol  | Meaning   |
|---|---|
|  | <b>Warning!</b><br>A warning highlights actions or procedures which, if not performed correctly, will lead to personal injury, a safety hazard or destruction of the instrument       |
|  | <b>Caution!</b><br>Caution highlights actions or procedures which, if not performed correctly, may lead to personal injury or incorrect functioning of the instrument                 |
|  | <b>Note!</b><br>A note highlights actions or procedures which, if not performed correctly, may indirectly affect operation or may lead to an instrument response which is not planned |

|   |   |
|---|---|
|    | <b>Device certified for use in explosion hazardous area</b><br>If the device has this symbol embossed on its name plate it can be installed in an explosion hazardous area  |
|  | <b>Explosion hazardous area</b><br>Symbol used in drawings to indicate explosion hazardous areas.<br>– Devices located in and wiring entering areas with the designation “explosion hazardous areas” must conform with the stated type of protection    |
|  | <b>Safe area (non-explosion hazardous area)</b><br>Symbol used in drawings to indicate, if necessary, non-explosion hazardous areas.<br>– Devices located in safe areas still require a certificate if their outputs run into explosion hazardous areas |

|   |   |
|---|---|
|  | <b>Direct voltage</b><br>A terminal to which or from which a direct current or voltage may be applied or supplied   |
|  | <b>Alternating voltage</b><br>A terminal to which or from which an alternating (sine-wave) current or voltage may be applied or supplied  |
|  | <b>Grounded terminal</b><br>A grounded terminal, which as far as the operator is concerned, is already grounded by means of an earth grounding system   |
|  | <b>Protective grounding (earth) terminal</b><br>A terminal which must be connected to earth ground prior to making any other connection to the equipment  |
|  | <b>Equipotential connection (earth bonding)</b><br>A connection made to the plant grounding system which may be of type e.g. neutral star or equipotential line according to national or company practice |

## 2 Identification

### 2.1 Device designation

#### 2.1.1 Nameplate

The following technical data are given on the instrument nameplate:

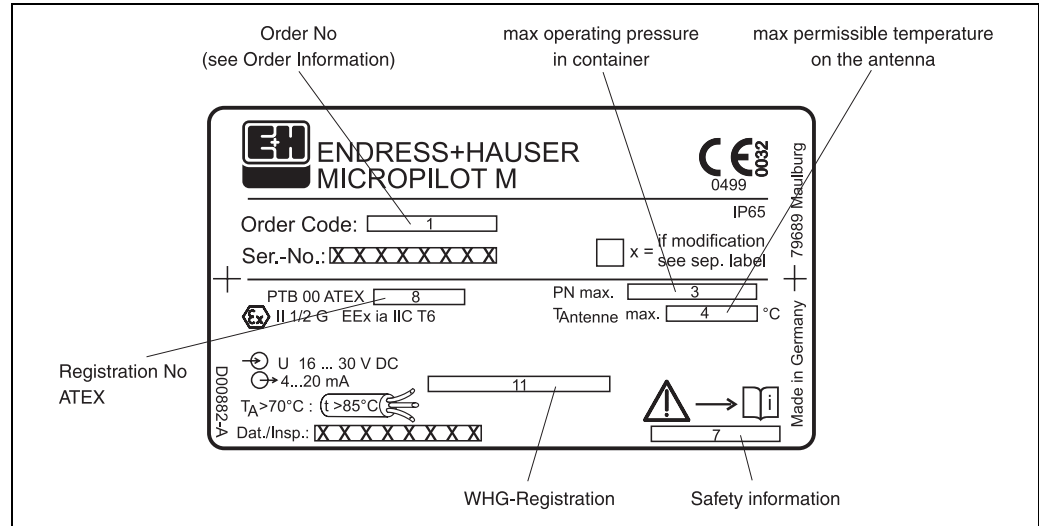

L00-FMR2xxxx-18-00-00-en-001

Fig. 1: Information on the nameplate of the Micropilot M (example)

#### 2.1.2 Ordering structure

##### Ordering structure Micropilot M FMR 245

|           |                     |   |
|-----------|---------------------|---|
| <b>10</b> | <b>Certificates</b> |   |
|           | A                   | For non-hazardous areas   |
|           | F                   | For non-hazardous areas + WHG   |
|           | 2                   | ATEX II 1/2 G EEx ia IIC T6, note safety instruction (XA) for electrostatic charging!       |
|           | 7                   | ATEX II 1/2 G EEx ia IIC T6 + WHG, note safety instruction (XA) for electrostatic charging! |
|           | 5                   | ATEX II 1/2 G EEx d [ia] IIC T6, note safety instruction (XA) for electrostatic charging!   |
|           | G                   | ATEX II 3 G EEx nA II T6, note safety instruction (XA) for electrostatic charging!          |
|           | S                   | FM IS - Class I, Division 1, Group A-D  |
|           | T                   | FM XP - Class I, Division 1, Group A-D  |
|           | N                   | CSA General Purpose   |
|           | U                   | CSA IS - Class I, Division 1, Group A-D   |
|           | V                   | CSA XP - Class I, Division 1, Group A-D   |
|           | K                   | TIIS EEx ia IIC T4  |
|           | L                   | TIIS EEx d [ia] IIC T4  |
|           | Y                   | Special version   |

|           |                     |                 |
|-----------|---------------------|-----------------|
| <b>20</b> | <b>Antenna size</b> |                 |
|           | 3                   | 50 mm / 2"      |
|           | 4                   | 80 mm / 3"      |
|           | 9                   | Special version |

|  |  |  |  |  |  |  |  |
|--|--|--|--|--|--|--|--|
|  |  |  |  |  |  |  |  |
|--|--|--|--|--|--|--|--|

FMR 245- Product designation (part 1)

**Ordering structure Micropilot M FMR 245 (continued)**

|                 |  |  |  |                          |                 |
|-----------------|--|--|--|--------------------------|-----------------|
| <b>30</b>       |  | <b>Process connection, material</b>    |  |                          |                 |
|                 |  |  | <i>Flange Dia/Pressure</i>   | <i>Standard</i>          | <i>Material</i> |
|                 |  | CFK                                    | DN50 PN16  | EN 1092-1 <sup>1)</sup>  | PTFE >316L      |
|                 |  | CMK                                    | DN80 PN16  | EN 1092-1 <sup>1)</sup>  | PTFE >316L      |
|                 |  | CQK                                    | DN100 PN16   | EN 1092-1 <sup>1)</sup>  | PTFE >316L      |
|                 |  | CWK                                    | DN150 PN16   | EN 1092-1 <sup>1)</sup>  | PTFE >316L      |
|                 |  | AEK                                    | 2"/150 lbs   | ANSI B16.5               | PTFE >316L      |
|                 |  | ALK                                    | 3"/150 lbs   | ANSI B16.5               | PTFE >316L      |
|                 |  | APK                                    | 4"/150 lbs   | ANSI B16.5               | PTFE >316L      |
|                 |  | AVK                                    | 6"/150 lbs   | ANSI B16.5               | PTFE >316L      |
|                 |  | KEK                                    | 10 K 50A   | JIS B2210                | PTFE >316L      |
|                 |  | KLK                                    | 10 K 80A   | JIS B2210                | PTFE >316L      |
|                 |  | KPK                                    | 10 K 100A  | JIS B2210                | PTFE >316L      |
|                 |  | KVK                                    | 10 K 150A  | JIS B2210                | PTFE >316L      |
|                 |  |  |  | 1) agreeable to DIN 2527 |                 |
|                 |  |  | <i>Sanitary Coupling</i>   | <i>Standard</i>          | <i>Material</i> |
|                 |  | TDK                                    | 2" Tri-clamp   | ISO 2852                 | PTFE >316L      |
|                 |  | TEK                                    | 2½" Tri-clamp  | ISO 2852                 | PTFE >316L      |
|                 |  | TFK                                    | 3" Tri-clamp   | ISO 2852                 | PTFE >316L      |
|                 |  | YY9                                    | Special version  |                          |                 |
| <b>40</b>       |  | <b>Output and menu based operation</b> |  |                          |                 |
|                 |  | A                                      | 4...20 mA HART with VU 331 (4-line alphanumeric display)   |                          |                 |
|                 |  | B                                      | 4...20 mA HART   |                          |                 |
|                 |  | K                                      | 4...20 mA HART, prepared for FHX40, mounting of remote display (accessory)                       |                          |                 |
|                 |  | C                                      | PROFIBUS PA with VU 331 (4-line alphanumeric display)  |                          |                 |
|                 |  | D                                      | PROFIBUS PA  |                          |                 |
|                 |  | L                                      | PROFIBUS PA, prepared for FHX40, mounting of remote display (accessory)                          |                          |                 |
|                 |  | E                                      | Foundation Fieldbus with VU 331 (4-line alphanumeric display)                                    |                          |                 |
|                 |  | F                                      | Foundation Fieldbus  |                          |                 |
|                 |  | M                                      | Foundation Fieldbus, prepared for FHX40, mounting of remote display (accessory)                  |                          |                 |
|                 |  | Y                                      | Special version  |                          |                 |
| <b>50</b>       |  | <b>Housing</b>                         |  |                          |                 |
|                 |  | A                                      | Aluminium F12-housing, coated, IP65  |                          |                 |
|                 |  | B                                      | 316L F23-housing, IP65/NEMA 4x   |                          |                 |
|                 |  | C                                      | Aluminium T12-housing with separate connection compartment, coated, IP65                         |                          |                 |
|                 |  | D                                      | Aluminium T12-housing with separate connection compartment, coated, IP65, overvoltage protection |                          |                 |
|                 |  | Y                                      | Special version  |                          |                 |
| <b>60</b>       |  | <b>Gland / Entry</b>                   |  |                          |                 |
|                 |  | 2                                      | M20x1.5 cable gland (for EEx d: cable entry)   |                          |                 |
|                 |  | 3                                      | G ½ cable entry  |                          |                 |
|                 |  | 4                                      | ½ NPT cable entry  |                          |                 |
|                 |  | 5                                      | PROFIBUS PA M12 plug   |                          |                 |
|                 |  | 6                                      | 7/8" FF plug   |                          |                 |
|                 |  | 9                                      | Special version  |                          |                 |
| <b>70</b>       |  | <b>Additional options</b>              |  |                          |                 |
|                 |  | A                                      | Additional options not selected  |                          |                 |
|                 |  | S                                      | GL (German Lloyd) marine certificate   |                          |                 |
|                 |  | Y                                      | Special version  |                          |                 |
| <b>FMR 245-</b> |  | Complete product designation           |  |                          |                 |

## 2.2 Scope of delivery



### Caution!

It is essential to follow the instructions concerning the unpacking, transport and storage of measuring instruments given in the chapter "Incoming acceptance, transport, storage" on Page 10!

The scope of delivery consists of:

- Assembled instrument
- 2 ToF Tool - FieldTool® Package CD-ROMs
  - CD 1: ToF Tool - FieldTool® Program
    - Program including Device Descriptions (device drivers) and documentation for all Endress+Hauser devices which are operable using ToF Tool
  - CD 2: ToF Tool - FieldTool® Utilities
    - Utility program (e.g. Adobe Acrobat Reader, MS Internet Explorer)
- Accessories (→ Chap. 8)

Accompanying documentation:

- Short manual (basic setup/troubleshooting): housed in the instrument
- Operating manual (this manual)
- Approval documentation: if this is not included in the operating manual.



### Note!

The operating manual "Description of Instrument Functions" you can be found on the enclosed CR-ROM.

## 2.3 Certificates and approvals

### CE mark, declaration of conformity

The instrument is designed to meet state-of-the-art safety requirements, has been tested and left the factory in a condition in which it is safe to operate. The instrument complies with the applicable standards and regulations in accordance with EN 61010 "Protection Measures for Electrical Equipment for Measurement, Control, Regulation and Laboratory Procedures". The instrument described in this manual thus complies with the statutory requirements of the EG directives. Endress+Hauser confirms the successful testing of the instrument by affixing to it the CE mark.

## 2.4 Registered trademarks

KALREZ®, VITON®, TEFLON®

Registered trademark of the company, E.I. Du Pont de Nemours & Co., Wilmington, USA

TRI-CLAMP®

Registered trademark of the company, Ladish & Co., Inc., Kenosha, USA

HART®

Registered trademark of HART Communication Foundation, Austin, USA

ToF®

Registered trademark of the company Endress+Hauser GmbH+Co. KG, Maulburg, Germany

PulseMaster®

Registered trademark of the company Endress+Hauser GmbH+Co. KG, Maulburg, Germany

PhaseMaster®

Registered trademark of the company Endress+Hauser GmbH+Co. KG, Maulburg, Germany



### 3 Mounting

#### 3.1 Quick installation guide



**Observe orientation when installing!**

**Installation in tank (free space):**

**Mark on process connector facing the nearest tank wall!**

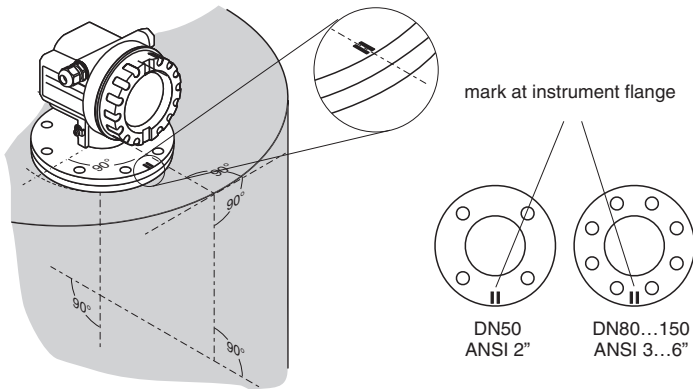

**Installation in stilling well:**

**Mark on process connector pointed towards the slots or vent holes!**

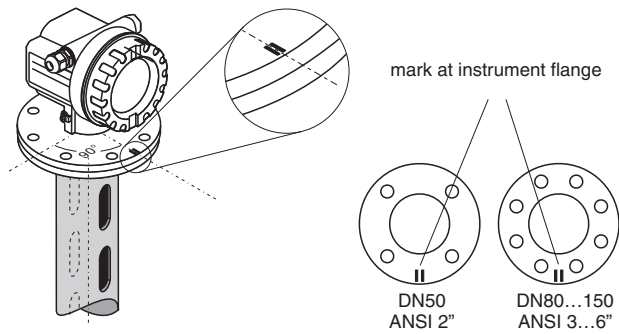

**Installation in bypass:**

**Mark on process connector 90° offset from the tank connections!**

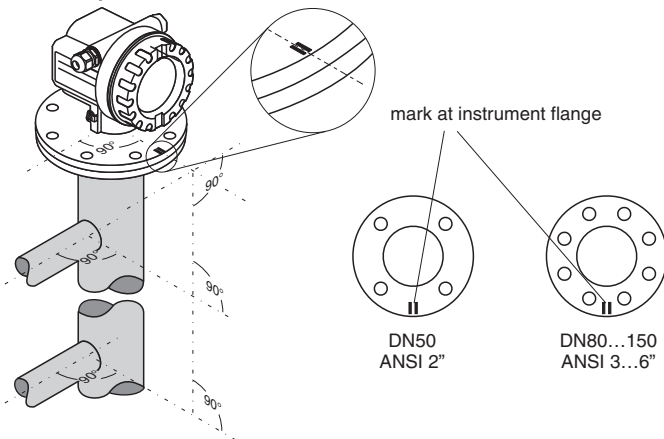

#### Turn housing

The housing can be turned 350° in order to simplify access to the display and the terminal compartment

##### F12/F23 housing

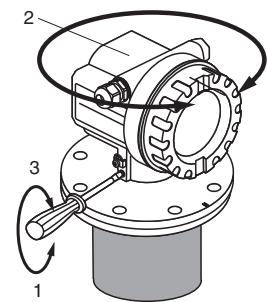

##### T12 housing

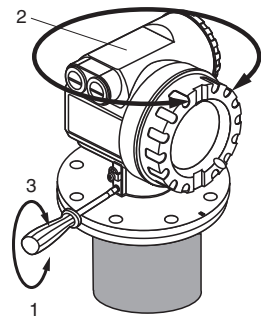

Allen key  
4 mm/0.1"

## 3.2 Incoming acceptance, transport, storage

### 3.2.1 Incoming acceptance

Check the packing and contents for any signs of damage.  
Check the shipment, make sure nothing is missing and that the scope of supply matches your order.

### 3.2.2 Transport



Caution!

Follow the safety instructions and transport conditions for instruments of more than 18 kg.

Do not lift the measuring instrument by its housing in order to transport it.

### 3.2.3 Storage

Pack the measuring instrument so that is protected against impacts for storage and transport. The original packing material provides the optimum protection for this.  
The permissible storage temperature is -40 °C...+80 °C.

### 3.3 Installation conditions

#### 3.3.1 Dimensions

##### Housing dimensions

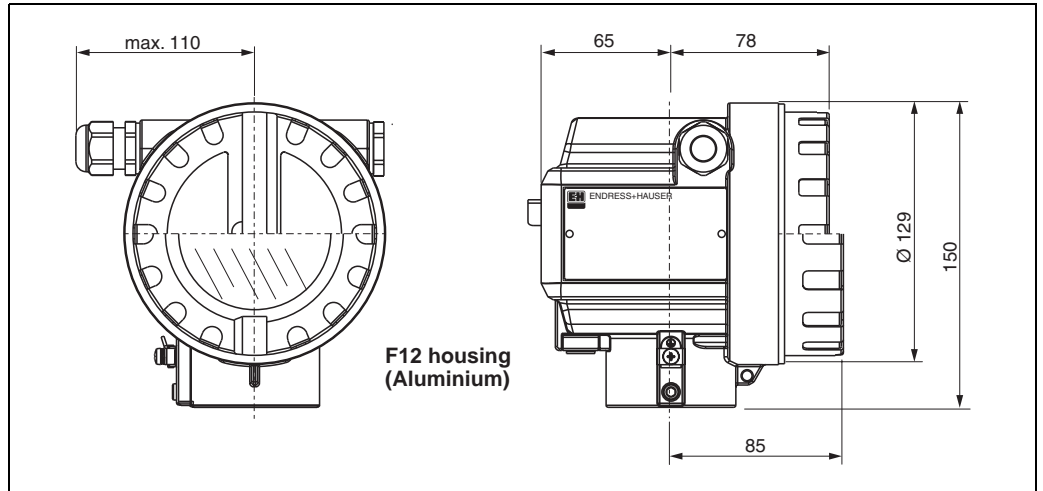

L00-F12xxxx-06-00-00-en-001

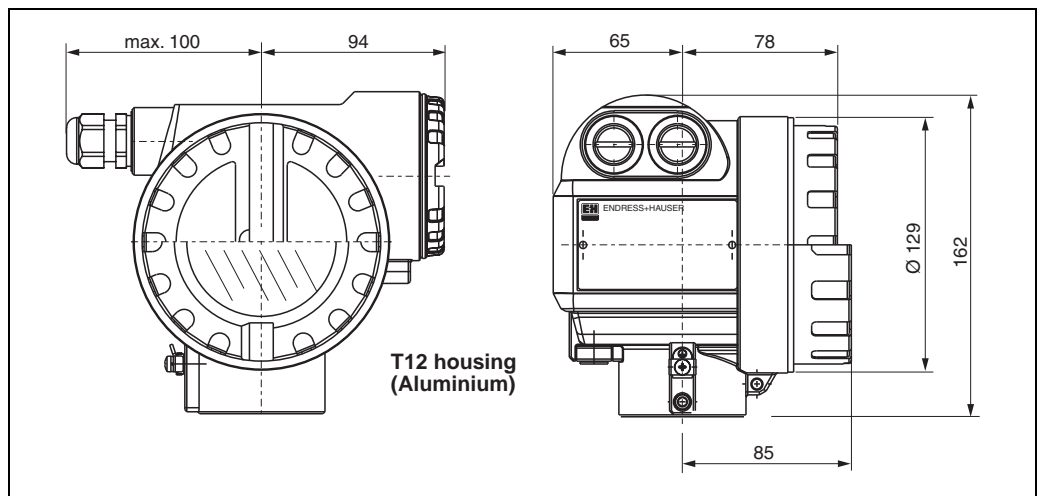

L00-T12xxxx-06-00-00-en-001

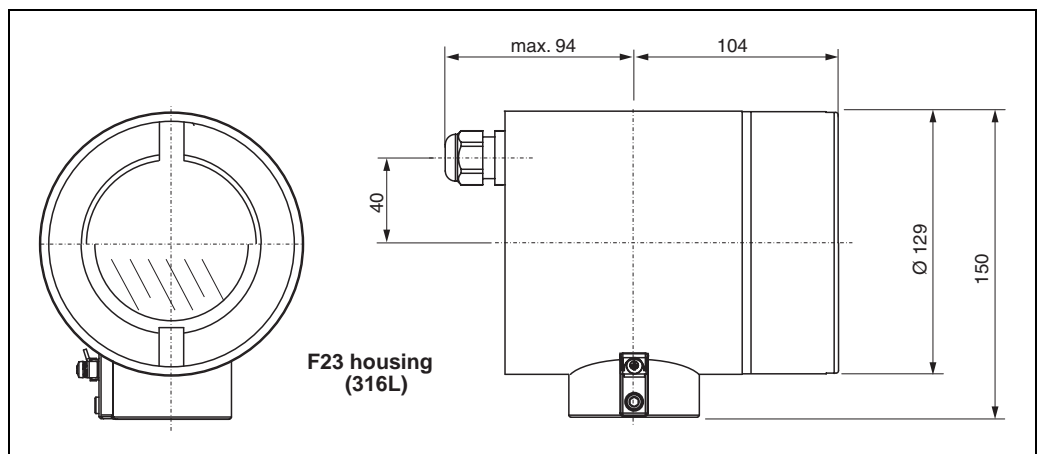

L00-F23xxxx-06-00-00-en-001

**Micropilot M FMR 245 - process connection, type of antenna**

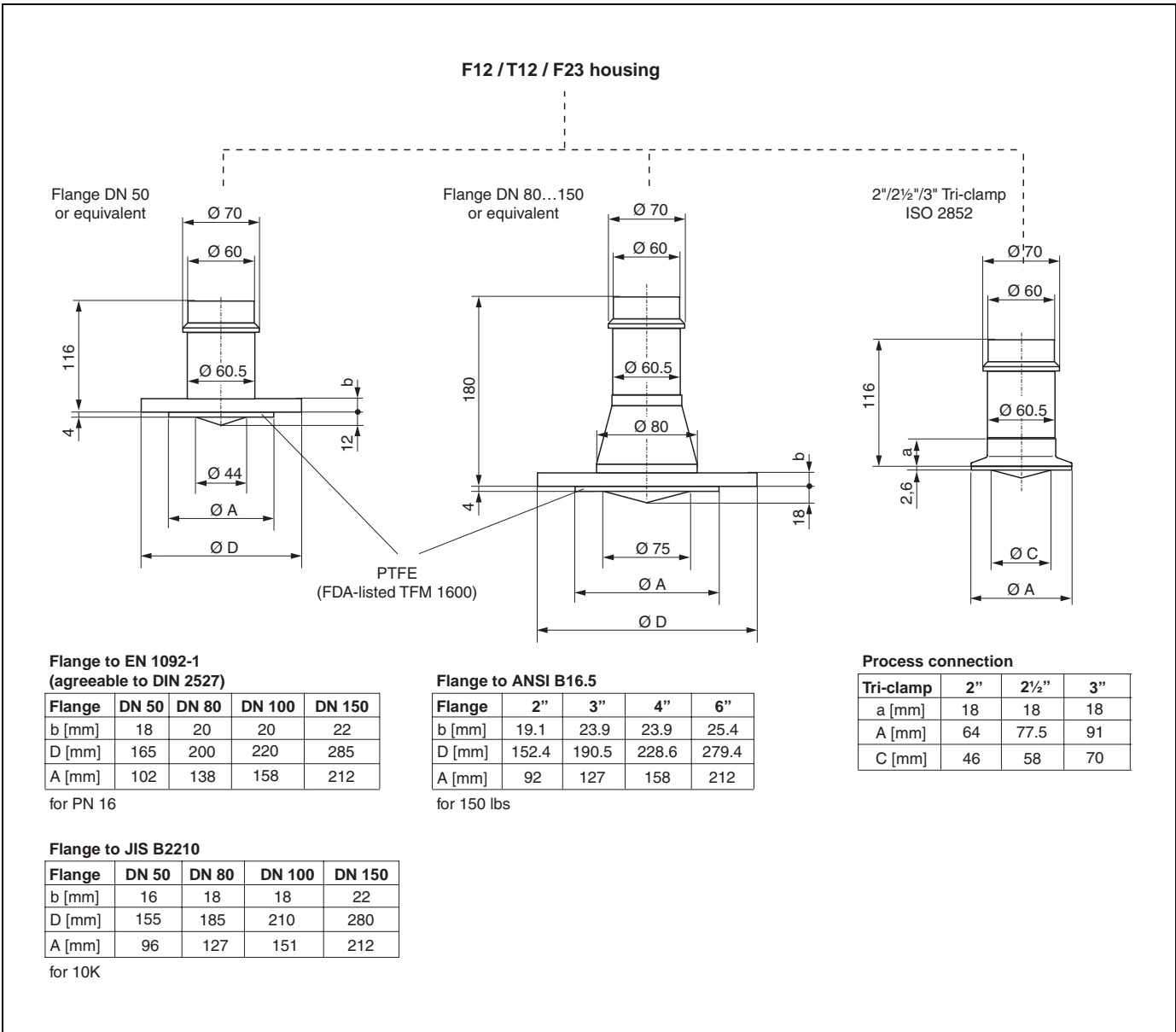

L00-FMR245xx-06-00-00-en-005

### 3.3.2 Engineering hints

#### Orientation

- Recommended distance (1) wall – **outer edge** of nozzle: ~1/6 of tank diameter. Nevertheless the device should not be installed closer than 15 cm (6") to the tank wall.
- Not in the centre (3), interference can cause signal loss.
- Not above the fill stream (4).
- It is recommended to use a weather protection cover (2) in order to protect the transmitter from direct sun or rain. Assembly and disassembly is simply done by means of a tension clamp (→ Chap. 8 on Page 61).

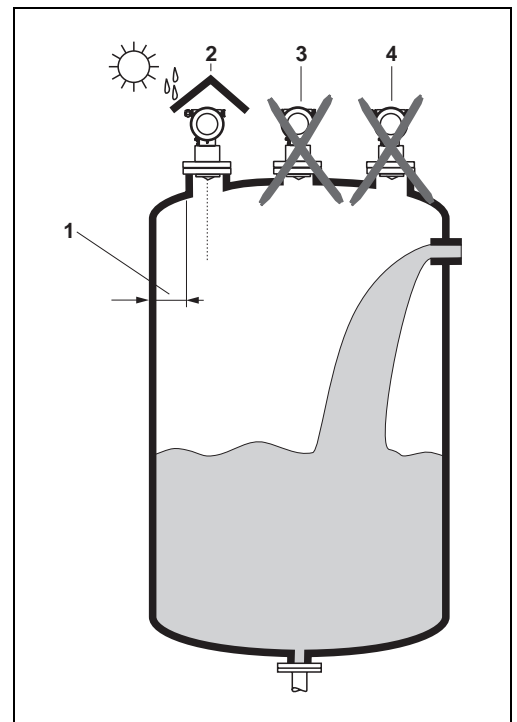

L00-FMR2xxxx-17-00-00-xx-010

#### Tank installations

- Avoid any installations (1), like limit switches, temperature sensors, etc., inside the signal beam (refer to beam angle see "Beam angle" on Page 14).
- Symmetrical installations (2), i.e. vacuum rings, heating coils, baffles, etc., can also interfere with the measurement.

#### Optimization options

- Antenna size: the bigger the antenna, the smaller the beam angle, the less interference echoes.
- Mapping: the measurement can be optimized by means of electronic suppression of interference echoes.
- Antenna alignment: refer to "optimum mounting position" (see Page 17/18/20).
- Stilling well: a stilling well respectively a Wave Guide antenna can always be used to avoid interference.

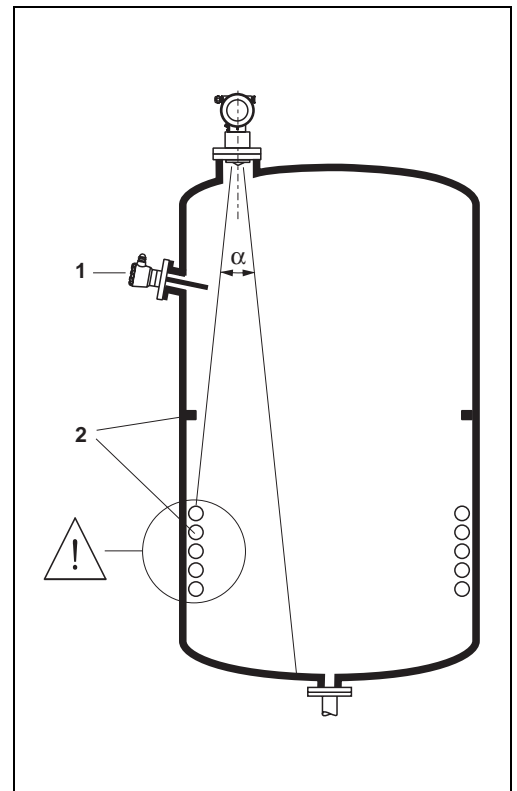

L00-FMR2xxxx-17-00-00-xx-011

Please contact Endress+Hauser for further information.

**Beam angle**

The beam angle is defined as the angle  $\alpha$  where the energy density of the radar waves reaches half the value of the maximum energy density (3dB-width). Microwaves are also emitted outside the signal beam and can be reflected off interfering installations. Beam diameter **W** as function of antenna type (beam angle  $\alpha$ ) and measuring distance **D**:

| Antenna size<br>(horn diameter) | FMR 245           |                   |
|---------------------------------|-------------------|-------------------|
|                                 |                   | 50 mm / 2"        |
| Beam angle $\alpha$             | 18°               | 10°               |
|                                 |                   |                   |
| Measuring distance (D)          | Beam diameter (W) |                   |
|                                 | 50 mm / 2"        | 80 mm / 3"        |
| 3 m / 10 ft                     | 0.95 m / 3.17 ft  | 0.52 m / 1.75 ft  |
| 6 m / 20 ft                     | 1.90 m / 6.34 ft  | 1.05 m / 3.50 ft  |
| 9 m / 30 ft                     | 2.85 m / 9.50 ft  | 1.57 m / 5.25 ft  |
| 12 m / 40 ft                    | 3.80 m / 12.67 ft | 2.10 m / 7.00 ft  |
| 15 m / 49 ft                    | 4.75 m / 15.52 ft | 2.62 m / 8.57 ft  |
| 20 m / 65 ft                    | —                 | 3.50 m / 11.37 ft |

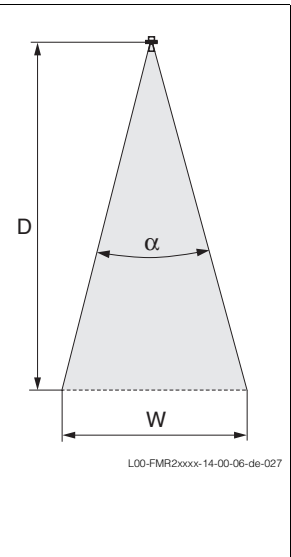

**Measuring conditions**



Note!

**Please use FMR 230 respectively FMR 231 for boiling surfaces or in case of a tendency for foaming. The maximum measuring range of the FMR245 may decrease in case of heavy steam development, depending on density, temperature and composition of the steam (→ please use FMR 230 respectively FMR 231). Please use FMR 230 in stilling well for the measurement of ammonia NH<sub>3</sub>.**

- The measuring range begins, where the beam hits the tank bottom. Particularly with dish bottoms or conical outlets the level cannot be detected below this point.
- In case of media with a low dielectric constant (groups A and B), the tank bottom can be visible through the medium at low levels. In order to guarantee the required accuracy in these cases, it is recommended to position the zero-point at a distance **C** above the tank bottom (see Fig.).
- For FMR 245 the end of measuring range should not be chosen closer than **A** (see Fig.) to the tip of the antenna, especially if there is development of condensate.
- The smallest possible measuring range **B** depends on the antenna version (see Fig.).
- The tank diameter should be greater than **D** (see Fig.), the tank height at least **H** (see Fig.).
- Depending on its consistence, foam can either absorb microwaves or reflect them off the foam surface. Measurement is possible under certain conditions.

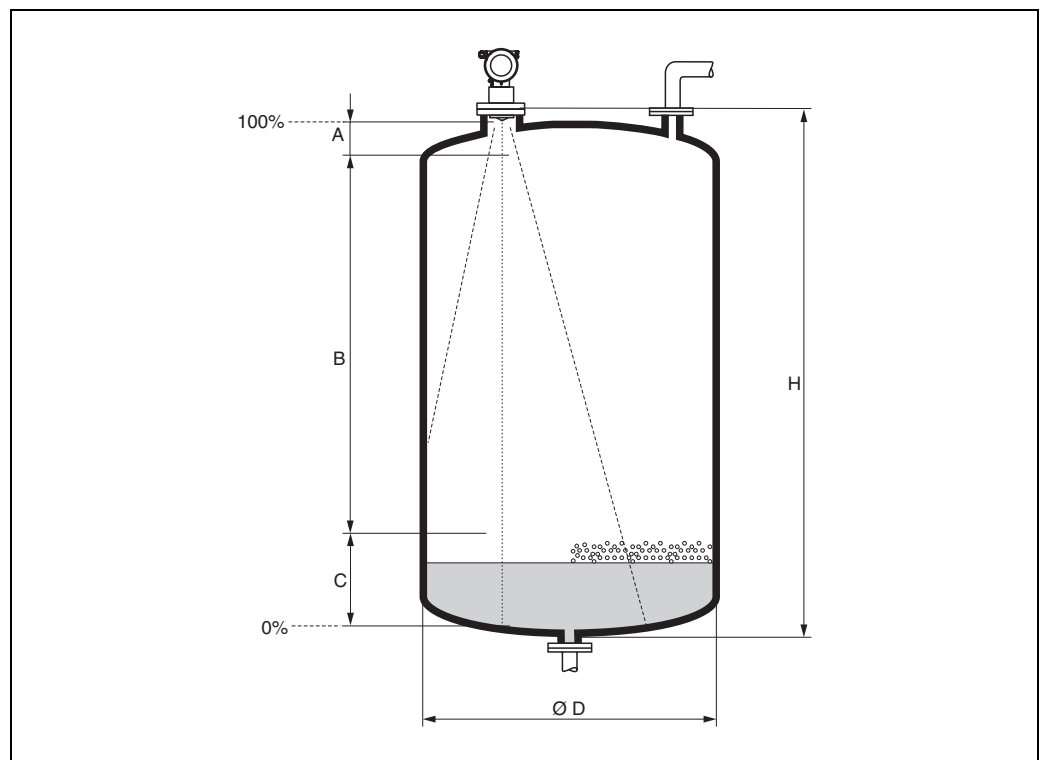

L00-FMR2xxxx-17-00-00-de-013

|                | A [mm/inch] | B [m/inch]  | C [m/inch]     | D [m/inch]  | H [m/ft]    |
|----------------|-------------|-------------|----------------|-------------|-------------|
| <b>FMR 245</b> | 200 / 8     | > 0,2 / > 8 | 50...150/2...6 | > 0,2 / > 8 | > 0,3 / > 1 |

**Measuring range**

The usable measuring range depends on the size of the antenna, the reflectivity of the medium, the mounting location and eventual interference reflections. The maximum configurable range is 20 m (65 ft) for all Micropilot M (larger ranges up to 35 m (114 ft) on request).

The following tables describe the groups of media as well as the achievable measuring range as a function of application and media group. If the dielectric constant of a medium is unknown, it is recommended to assume media group B to ensure a reliable measurement.

| Product class | DK ( $\epsilon_r$ ) | Examples  |
|---------------|---------------------|---|
| <b>A</b>      | 1,4...1,9           | non-conducting liquids, e.g. liquefied gas <sup>1)</sup>                          |
| <b>B</b>      | 1,9...4             | non-conducting liquids, e.g. benzene, oil, toluene, ...                           |
| <b>C</b>      | 4...10              | e.g. concentrated acids, organic solvents, esters, aniline, alcohol, acetone, ... |
| <b>D</b>      | > 10                | conducting liquids, e.g. aqueous solutions, dilute acids and alkalis              |

1) Treat Ammonia NH<sub>3</sub> as a medium of group A, i.e. use FMR 230 in a stilling well.

**Measuring range depending on vessel type, conditions and product for Micropilot M FMR 245**

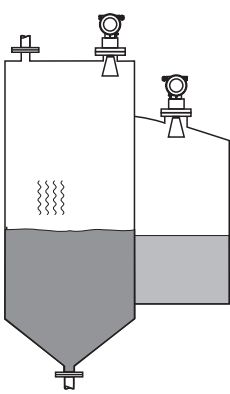
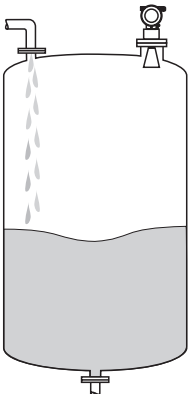
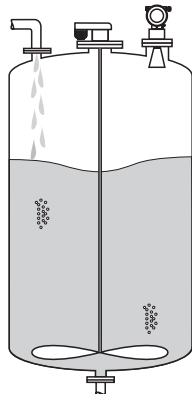
| Product class              | Storage tank<br>Calm product surface<br>(e.g. intermittent filling, filling from bottom, immersion tubes). |  | Buffer tank<br>Moving surfaces<br>(e.g. continuous filling, from above, mixing jets). |             | Process tank with agitator<br>Turbulent surface.<br>Single stage agitator<br><60 RPM. |            | Stilling well   | Bypass          |                               |
|----------------------------|--|--|---|-------------|---|------------|-----------------|-----------------|-------------------------------|
|                            |                         |  |    |             |   |            |                 |                 |                               |
|                            | Measuring range  |  | Measuring range   |             | Measuring range   |            | Measuring range | Measuring range |                               |
| <b>FMR 245 (horn dia):</b> | 50 mm / 2"   | 80 mm / 3"   | 50 mm / 2"  | 80 mm / 3"  | 50 mm / 2"  | 80 mm / 3" | 50 mm / 2"      | 80 mm / 3"      |                               |
| <b>A</b>                   | DK( $\epsilon_r$ )=1,4...1,9   | to use a stilling well (20 m / 65 ft) or Wave Guide antenna <sup>1</sup> (3.8 m / 12.5 ft) |   |             |   |            |                 | 20 m / 65 ft    | to use the Wave Guide antenna |
| <b>B</b>                   | DK( $\epsilon_r$ )=1,9...4   | 5 m / 16 ft  | 10 m / 33 ft  | 2,5 m       | 5 m / 16 ft   | 1,5 m      | 2 m             | 20 m / 65 ft    | to use the Wave Guide antenna |
| <b>C</b>                   | DK( $\epsilon_r$ )=4...10  | 10 m / 33 ft   | 15 m  | 5 m / 16 ft | 7,5 m   | 2 m        | 3 m             | 20 m / 65 ft    | 20 m / 65 ft                  |
| <b>D</b>                   | DK( $\epsilon_r$ )>10  | 15 m   | 20 m / 65 ft  | 7,5 m       | 10 m / 33 ft  | 3 m        | 5 m / 16 ft     | 20 m / 65 ft    | 20 m / 65 ft                  |

1) In the event of horizontal stress (e.g. agitators), mechanical support is required or provide the Wave Guide antenna with a protective pipe.



### 3.4 Installation instructions

#### 3.4.1 Mounting kit

In addition to the tool needed for flange mounting, you will require the following tool:

- 4 mm/0.1" Allen wrench for turning the housing.

#### 3.4.2 Installation in tank (free space)

##### Optimum mounting position

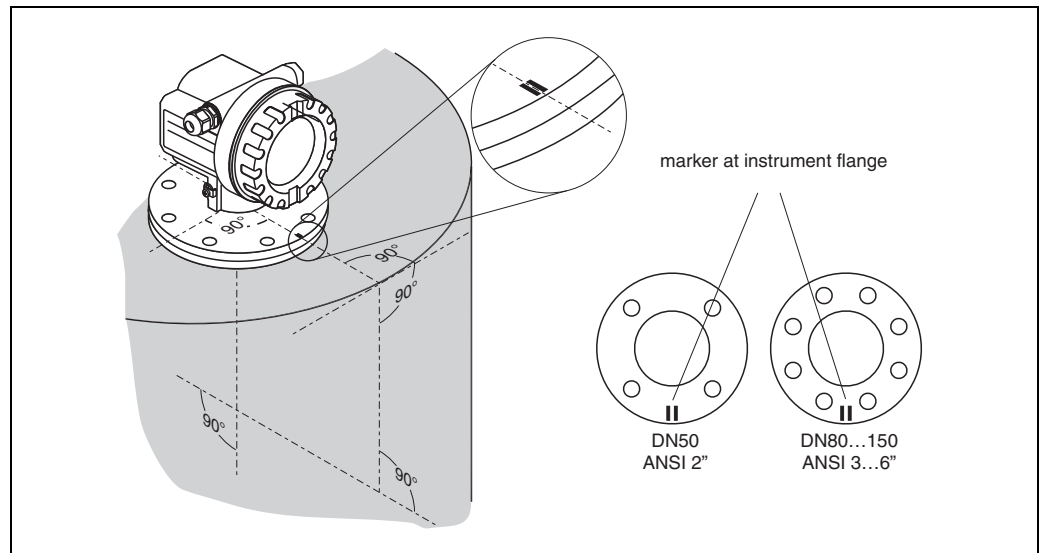

L00-FMR245xx-17-00-00-en-003

##### Standard installation

When mounting in a tank, please observe engineering hints on Page 13 and the following points:

- Marker is aligned towards tank wall.
- The marker is always exactly in the middle between two bolt-holes in the flange.
- Use spring washers (1).

Note!

It is recommended to retighten the flange bolts periodically, depending on process temperature and pressure.

- After mounting, the housing can be turned 350° in order to simplify access to the display and the terminal compartment.
- **The antenna must be aligned vertically.**

Caution!

The maximum range may be reduced, if the antenna is not vertically aligned.

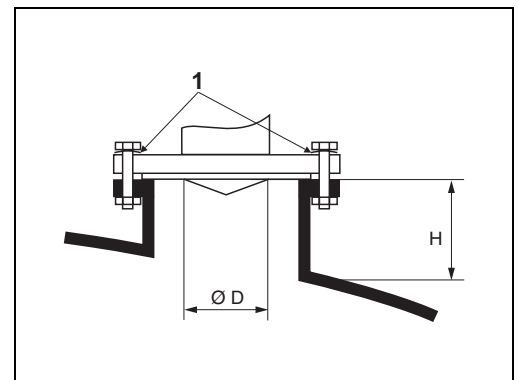

L00-FMR245xx-17-00-00-de-002

| Antenna size | 50 mm / 2"   | 80 mm / 3"   |
|--------------|--------------|--------------|
| D [mm/inch]  | 44 / 1.8     | 75 / 3       |
| H [mm/inch]  | < 500 / < 20 | < 500 / < 20 |



Note!

Please contact Endress+Hauser for application with higher nozzle.

### 3.4.3 Installation in stilling well

#### Optimum mounting position

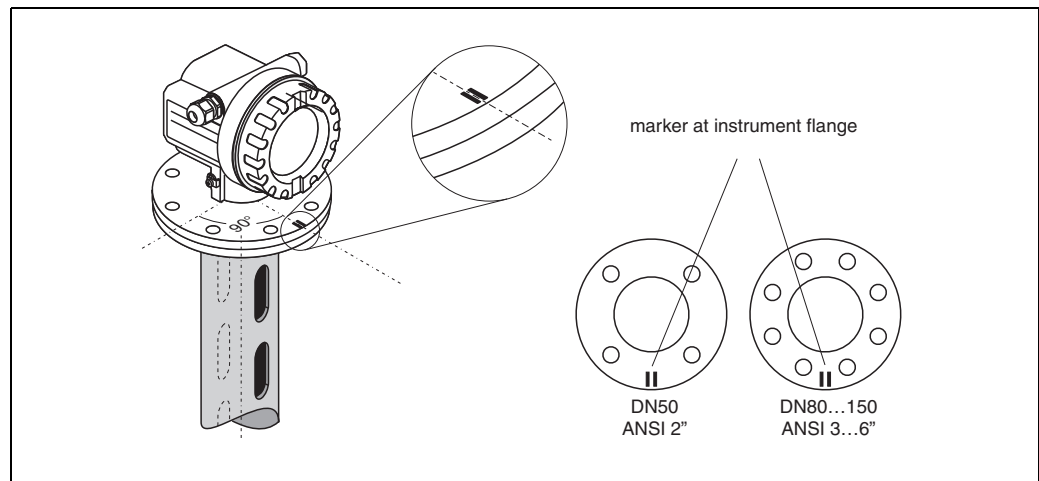

L00-FMR245xx-17-00-00-en-004

#### Standard installation

For installations in a stilling well, follow the engineering hints on Page 13 and note the following points:

- Marker is aligned toward slots.
- The marker is always exactly in the middle between two bolt-holes in the flange.
- After mounting, the housing can be turned 350° in order to simplify access to the display and the terminal compartment.
- Measurements can be performed through an open full bore ball valve without any problems.

#### Recommendations for the stilling well

At the construction of a stilling well, please note the following points:

- Metal (no enamel coating, plastic coating on request).
- Constant diameter.
- Stilling well diameter not larger than antenna diameter.
- Weld seam as smooth as possible and on the same axis as the slots.
- Slots offset 180° (not 90°).
- Slot width respectively diameter of holes max. 1/10 of pipe diameter, de-burred. Length and number do not have any influence on the measurement.
- At any transition (i.e. when using a ball valve or mending pipe segments), no gap may be created exceeding 1 mm.
- The stilling well must be smooth on the inside (average roughness  $R_z \leq 6.3 \mu\text{m}$ ). Use extruded or parallel welded stainless steel pipe. An extension of the pipe is possible with welded flanges or pipe sleeves. Flange and pipe have to be properly aligned at the inside.
- Do not weld through the pipe wall. The inside of the stilling well must remain smooth. In case of unintentional welding through the pipe, the weld seam and any unevenness on the inside need to be carefully removed and smoothed. Otherwise, strong interference echoes will be generated and material build-up will be promoted.

Examples for the construction of stilling wells

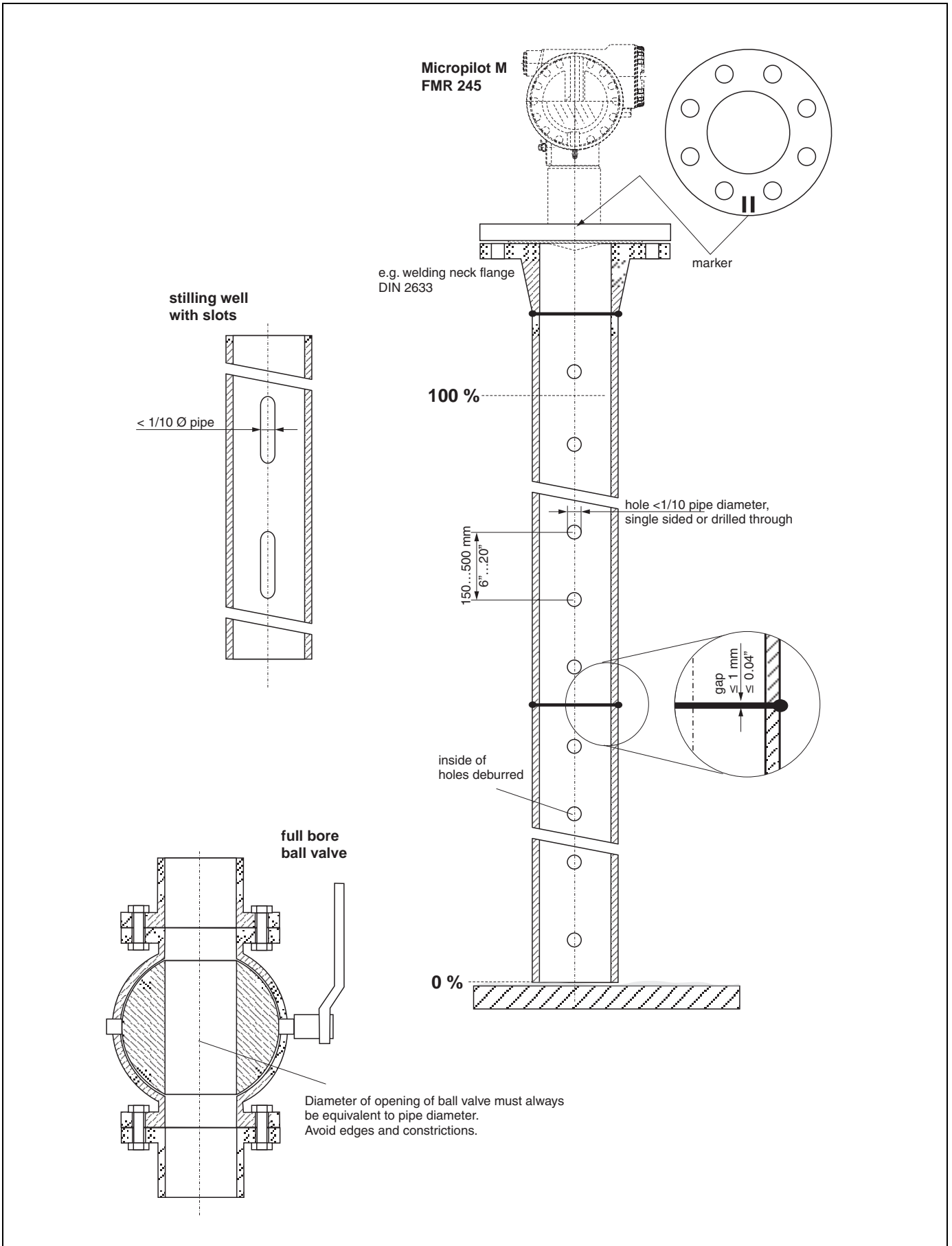

L00-FMR245xx-17-00-00-en-006

### 3.4.4 Installation in bypass

#### Optimum mounting position

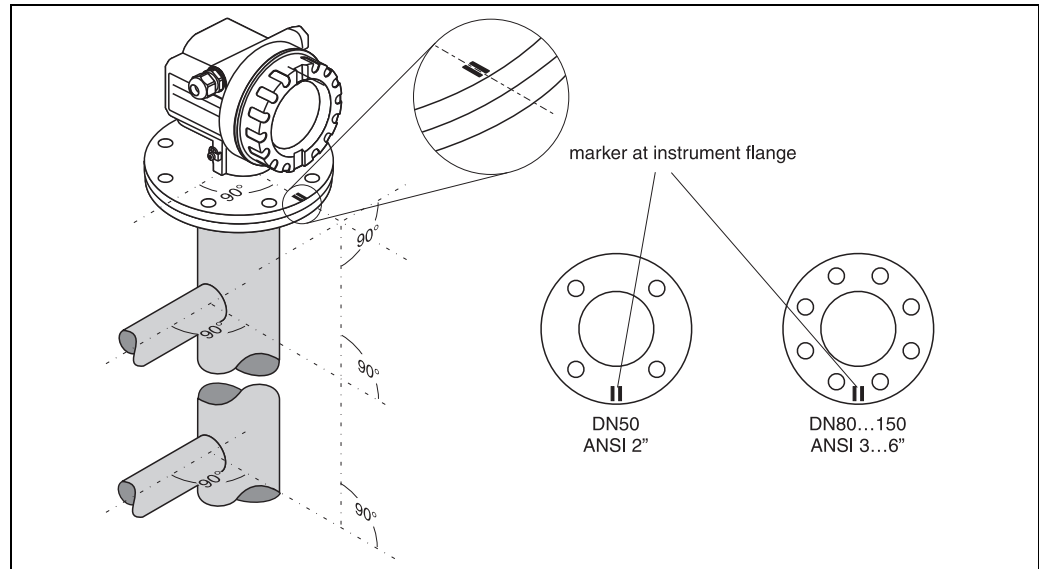

L00-FMR230xx-17-00-00-en-007

#### Standard installation

For installations in a bypass, follow the engineering hints on Page 13 and note the following points:

- Marker is aligned perpendicular (90°) to tank connectors.
- The marker is always exactly in the middle between two bolt-holes in the flange.
- After mounting, the housing can be turned 350° in order to simplify access to the display and the terminal compartment.
- Measurements can be performed through an open full bore ball valve without any problems.

#### Recommendations for the bypass pipe

- Metal (no plastic or enamel coating)
- Constant diameter
- Select horn antenna as big as possible. For intermediate sizes (i.e. 95 mm) select next larger antenna and adapt it mechanically (FMR 230 / FMR 240 only).
- At any transition (i.e. when using a ball valve or mending pipe segments), no gap may be created exceeding 1 mm (0.04").
- In the area of the tank connections (~ ±20 cm / 8") a reduced accuracy of the measurement has to be expected.

**Example for the construction of a bypass.**

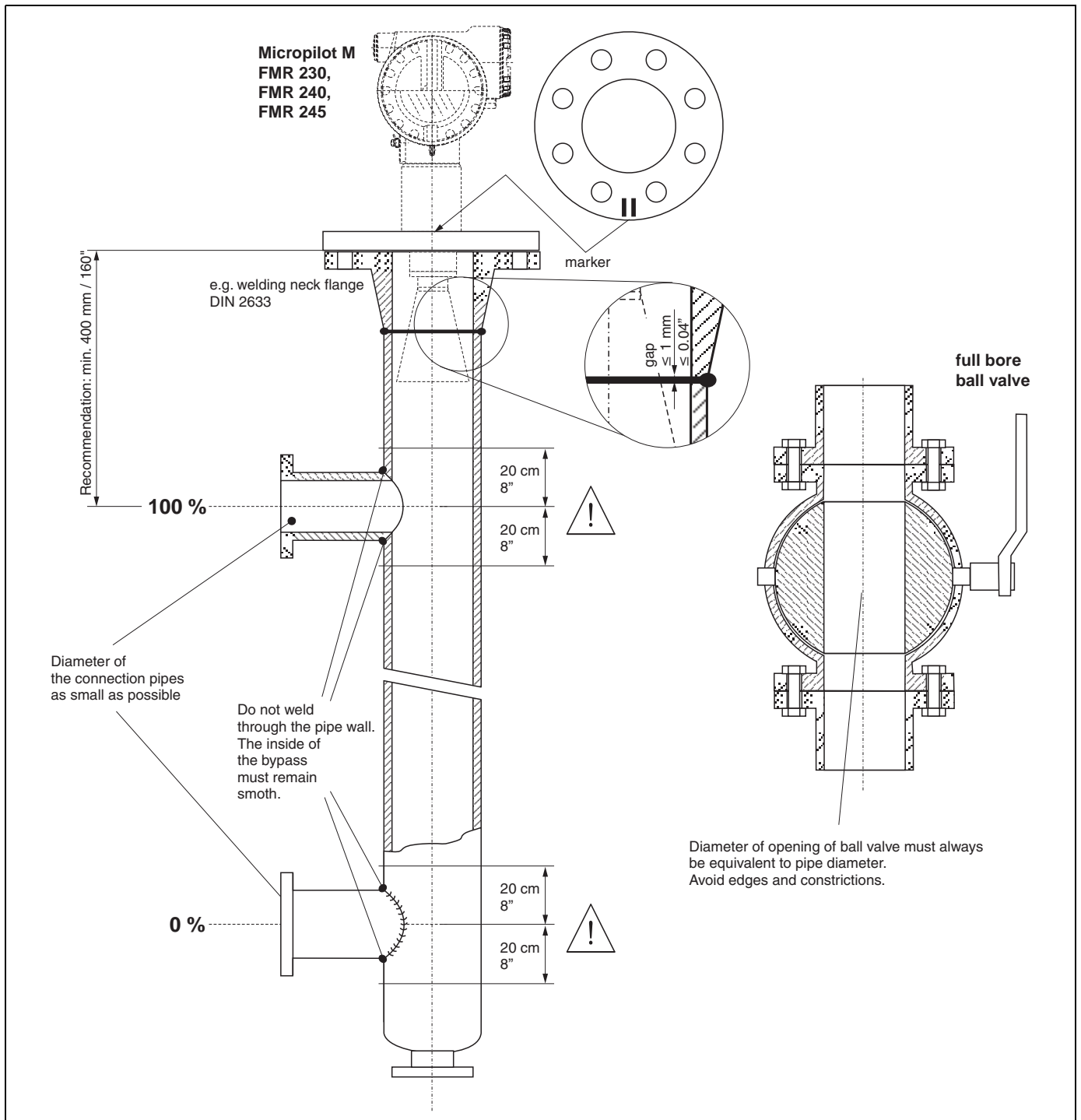

L00-FMR2xxxx-17-00-00-en-019

### 3.4.5 Turn housing

After mounting, the housing can be turned 350° in order to simplify access to the display and the terminal compartment. Proceed as follows to turn the housing to the required position:

- Undo the fixing screws (1)
- Turn the housing (2) in the required direction
- Tighten up the fixing screws (1)

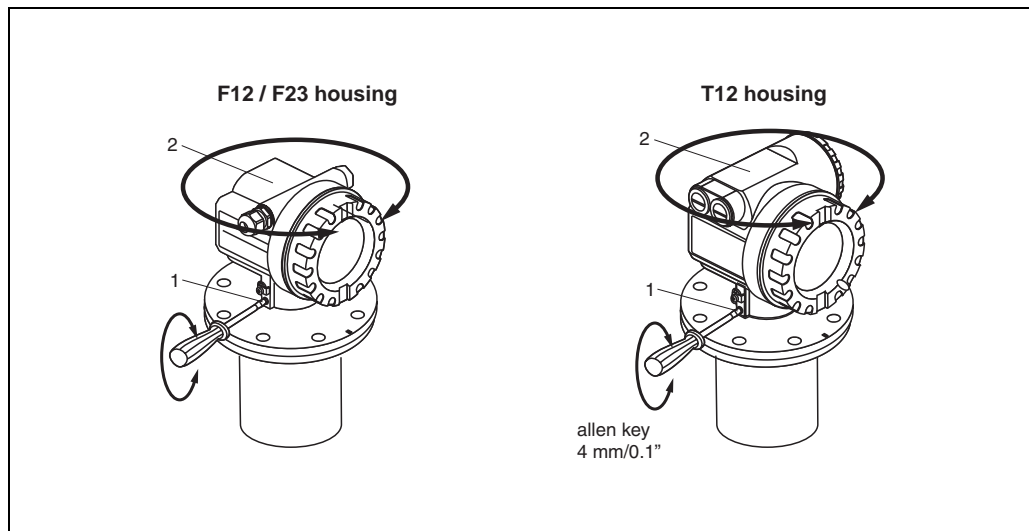

L00-FMR2xxxx-17-00-00-en-010

### 3.5 Post-installation check

After the measuring instrument has been installed, perform the following checks:

- Is the measuring instrument damaged (visual check)?
- Does the measuring instrument correspond to the measuring point specifications such as process temperature/pressure, ambient temperature, measuring range, etc.?
- Is the flange marking correctly aligned? (→ Page 9)
- Have the flange screws been tightened up with the respective tightening torque?
- Are the measuring point number and labeling correct (visual check)?
- Is the measuring instrument adequately protected against rain and direct sunlight (→ Page 61)?

# 4 Wiring

## 4.1 Quick wiring guide

### Wiring in F12/F23 housing



Before connection please note the following:

- The power supply must be identical to the data on the nameplate (1).
- Switch off power supply before connecting up the device.
- Connect Equipotential bonding to transmitter ground terminal before connecting up the device.
- Tighten the locking screw: It forms the connection between the antenna and the housing ground potential.

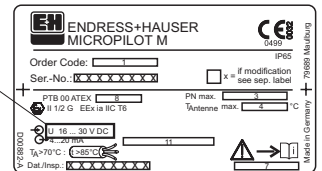

When you use the measuring system in hazardous areas, make sure you comply with national standards and the specifications in the safety instructions (XA's). Make sure you use the specific cable gland.



On devices supplied with a certificate, the explosion protection is designed as follows:

- Housing F12/F23 - EEx ia: Power supply must be intrinsically safe.
- The electronics and the current output are galvanically separated from the antenna circuit.

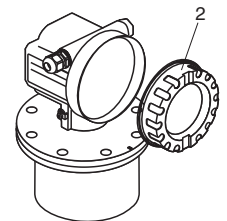

Connect up the Microplot M as follows:

- Unscrew housing cover (2).
- Remove any display (3) if fitted.
- Remove cover plate from terminal compartment (4).
- Pull out terminal module slightly using pulling loop.
- Insert cable (5) through gland (6).  
A standard installation cable is sufficient if only the analogue signal is used. Use a screened cable when working with a superimposed communications signal (HART).



Unplug display connector!

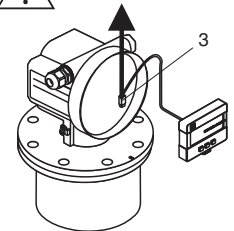

Only ground screening of the line (7) on sensor side.

- Make connection (see pin assignment).
- Re-insert terminal module.
- Tighten cable gland (6).
- Tighten screws on cover plate (4).
- Insert display if fitted.
- Screw on housing cover (2).
- Switch on power supply.

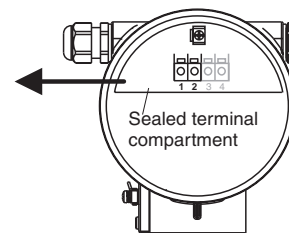
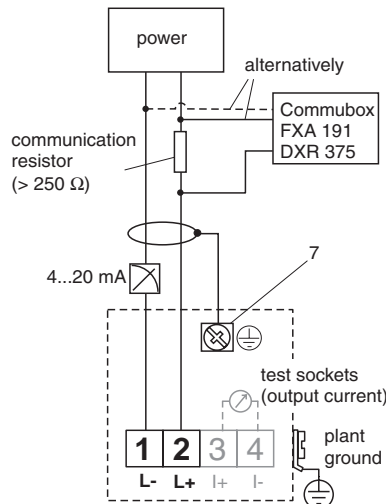
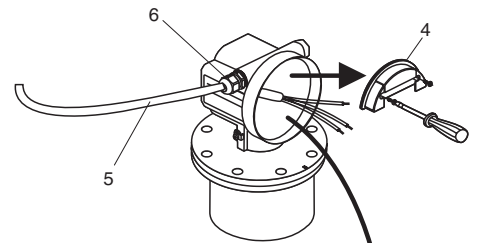

**Wiring in T12 housing**



Before connection please note the following:

- The power supply must be identical to the data on the nameplate (1).
- Switch off power supply before connecting up the device.
- Connect Equipotential bonding to transmitter ground terminal before connecting up the device.
- Tighten the locking screw: It forms the connection between the antenna and the housing ground potential.

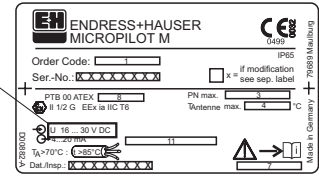

When you use the measuring system in hazardous areas, make sure you comply with national standards and the specifications in the safety instructions (XA's). Make sure you use the specific cable gland.



Connect up the Micropilot M as follows:

Before unscrew housing cover (2) at separate connection room turn off the power supply!

- Insert cable (3) through gland (4). A standard installation cable is sufficient if only the analogue signal is used. Use a screened cable when working with a superimposed communications signal (HART).

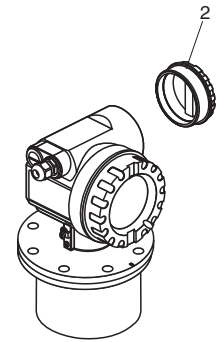

Only ground screening of the line (5) on sensor side.

- Make connection (see pin assignment).
- Tighten cable gland (4).
- Screw on housing cover (2).
- Switch on power supply.

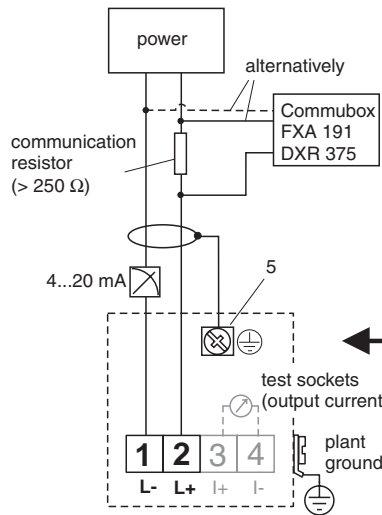
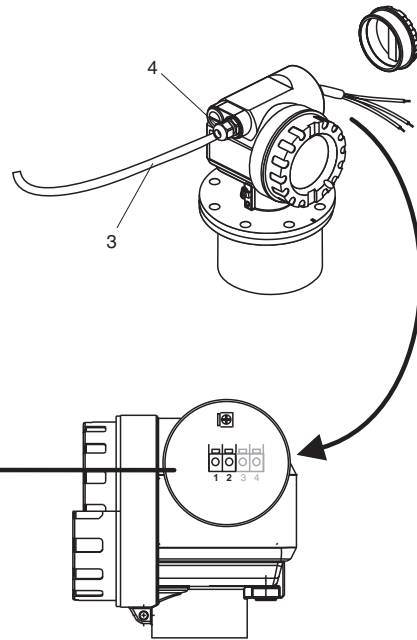

L00-FMR2xxxx-04-00-00-en-014



## 4.2 Connecting the measuring unit

### Terminal compartment

Three housings are available:

- Aluminium housing F12 with additionally sealed terminal compartment for:
  - standard,
  - EEx ia.
- Aluminium housing T12 with separate terminal compartment for:
  - standard,
  - EEx e,
  - EEx d,
  - EEx ia (with overvoltage protection).
- 316L housing F23 for:
  - standard,
  - EEx ia.

The electronics and current output are galvanically isolated from the antenna circuit.

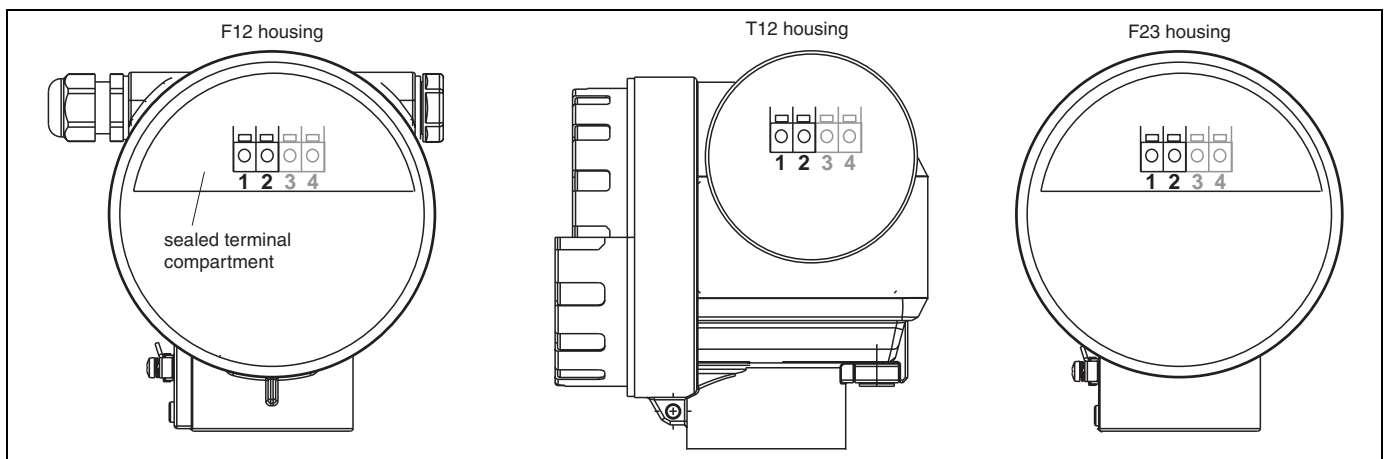

The instrument data are given on the nameplate together with important information regarding the analog output and voltage supply. Housing orientation regarding the wiring, (→ Page 22).

### Load HART

Minimum load for Hart communication: 250  $\Omega$

### Cable entry

Cable gland: M20x1.5

Cable entry: G ½ or ½ NPT

### Supply voltage

The following values are the voltages across the terminals directly at the instrument:

| Communication   |                 | Current consumption | Terminal voltage |         |
|---|-----------------|---------------------|------------------|---------|
|   |                 |                     | minimal          | maximal |
| HART  | standard        | 4 mA                | 16 V             | 36 V    |
|   |                 | 20 mA               | 7.5 V            | 36 V    |
|   | EEx ia          | 4 mA                | 16 V             | 30 V    |
|   |                 | 20 mA               | 7.5 V            | 30 V    |
|   | EEx em<br>EEx d | 4 mA                | 16 V             | 30 V    |
|   |                 | 20 mA               | 11 V             | 30 V    |
| Fixed current,<br>adjustable e.g. for<br>solar power operation<br>(measured value<br>transferred at HART) | standard        | 11 mA               | 10 V             | 36 V    |
|   | EEx ia          | 11 mA               | 10 V             | 30 V    |
| Fixed current for HART<br>Multidrop mode  | standard        | 4 mA <sup>1)</sup>  | 16 V             | 36 V    |
|   | EEx ia          | 4 mA <sup>1)</sup>  | 16 V             | 30 V    |

1) Start up current 11 mA.

### Power consumption

Normal operation: min. 60 mW, max. 900 mW

### Current consumption

| Communication | Current consumption |
|---------------|---------------------|
| HART          | 3.6...22 mA         |

### 4.2.1 HART connection with E+H RMA 422 / RN 221 N

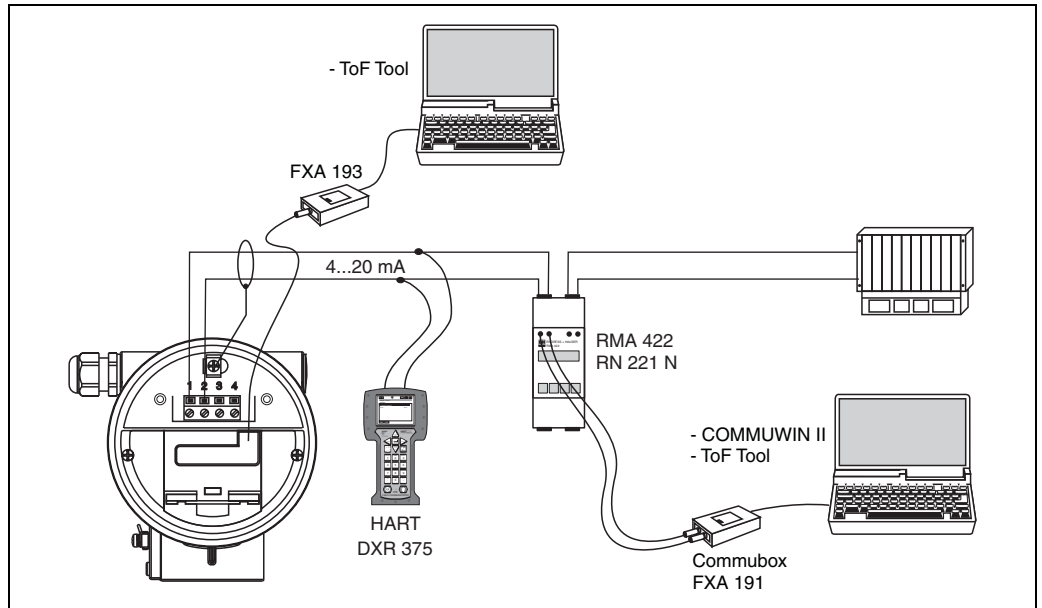

### 4.2.2 HART connection with other supplies

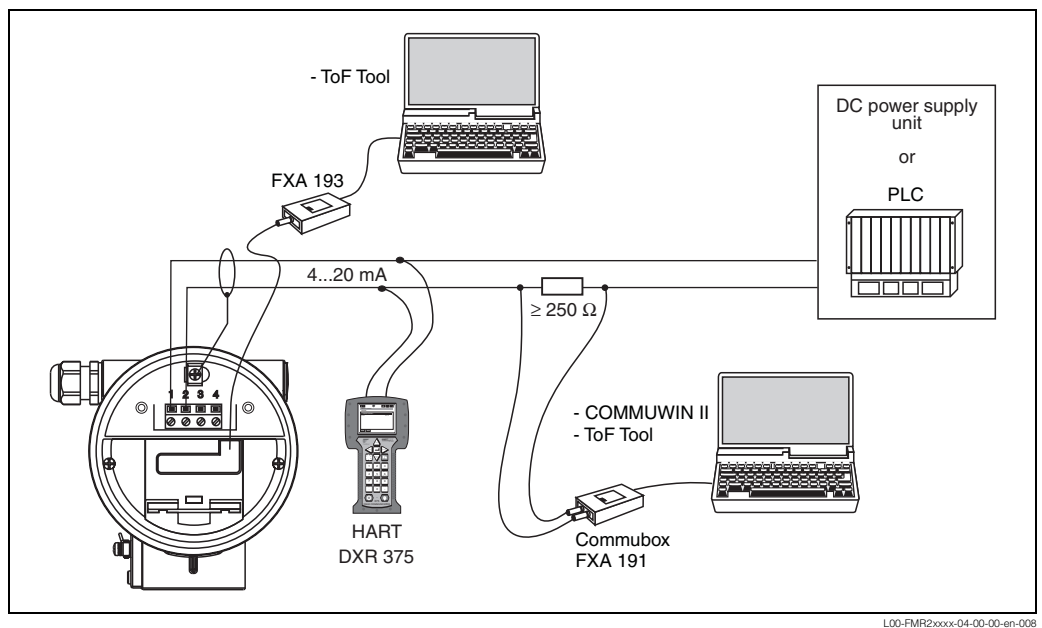

**Caution!**

If the HART communication resistor is not built into the supply unit, it is necessary to insert a communication resistor of 250 Ω into the 2-wire line.

## 4.3 Recommended connection

### 4.3.1 Equipotential bonding

Connect the equipotential bonding to the external ground terminal of the transmitter.

### 4.3.2 Wiring screened cable



Caution!

In Ex applications, the screen must only be grounded on the sensor side. Further safety instructions are given in the separate documentation for applications in explosion hazardous areas.

## 4.4 Degree of protection

- housing: IP 65, NEMA 4X (open housing and pulled out display: IP20, NEMA 1)
- antenna: IP 68 (NEMA 6P)

## 4.5 Post-connection check

After wiring the measuring instrument, perform the following checks:

- Is the terminal allocation correct (→ Page 23 and Page 24)?
- Is the cable gland tight?
- Is the housing cover screwed tight?
- If auxiliary power is available:  
Is the instrument ready for operation and does the liquid crystal display show any value?

# 5 Operation

## 5.1 Quick operation guide

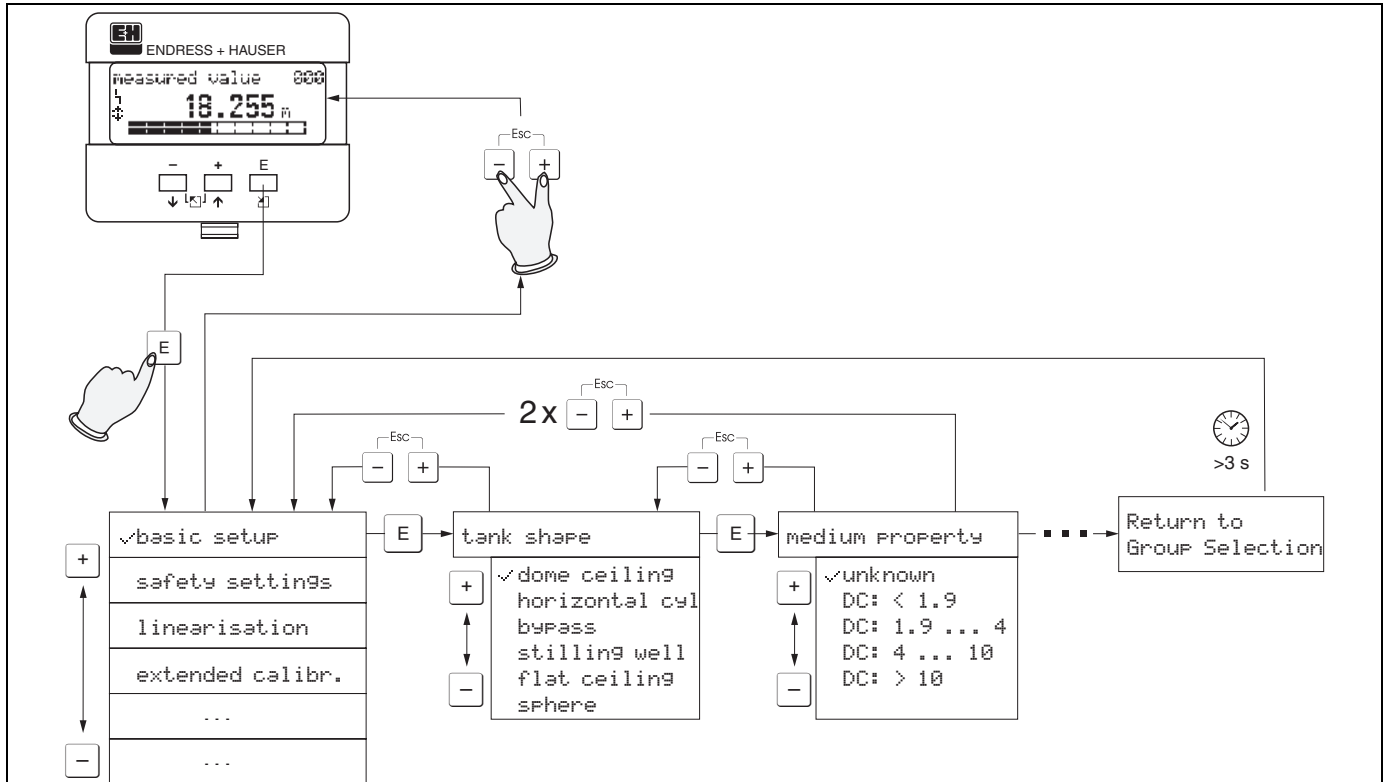

### Selection and configuration in Operation menu:

- 1.) Change from Measured Value Display to **Group Selection** by pressing **E**
- 2.) Press **-** or **+** to select the required **Function Group** (e.g. "basic setup (00)") and confirm by pressing **E** → First function (e.g. "tank shape (002)") is selected.

#### Note!

The active selection is marked by a ✓ in front of the menu text.

- 3.) Activate Edit mode with **+** or **-**.

#### Selection menus:

- a) Select the required **Parameter** in selected **function** (e.g. "tank shape (002)") with **-** or **+**.
- b) **E** confirms selection → ✓ appears in front of the selected parameter
- c) **E** confirms the edited value → system quits Edit mode
- d) **+** + **-** (= **Esc**) interrupts selection → system quits Edit mode

#### Typing in numerals and text:

- a) Press **+** or **-** to edit the first character of the **numeral / text** (e.g. "empty calibr. (005)")
  - b) **E** positions the cursor at the next character → continue with (a) until you have completed your input
  - c) if a **¶** symbol appears at the cursor, press **E** to accept the value entered → system quits Edit mode
  - d) **+** + **-** (= **Esc**) interrupts the input, system quits Edit mode
- 4) Press **E** to select the next **function** (e.g. "medium property (003)")
  - 5) Press **+** + **-** (= **Esc**) once → return to previous **function** (e.g. "tank shape (002)")  
 Press **+** + **-** (= **Esc**) twice → return to **Group selection**
  - 6) Press **+** + **-** (= **Esc**) to return to **Measured value display**



## 5.2 Display and operating elements

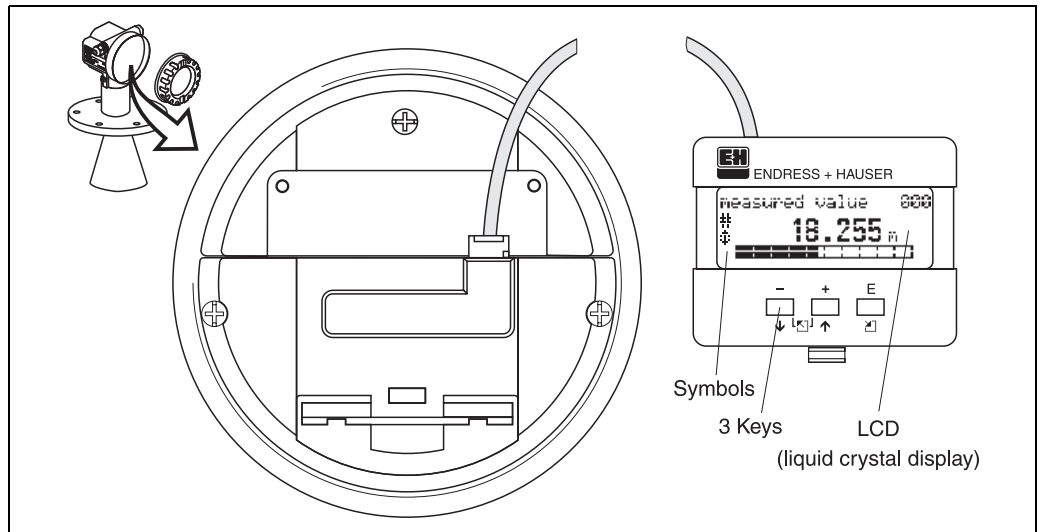

Fig. 2: Layout of the display and operating elements



Note!

To access the display the cover of the electronic compartment may be removed even in hazardous area (IS and XP).

### 5.2.1 Display

#### Liquid crystal display (LCD):

Four lines with 20 characters each. Display contrast adjustable through key combination.

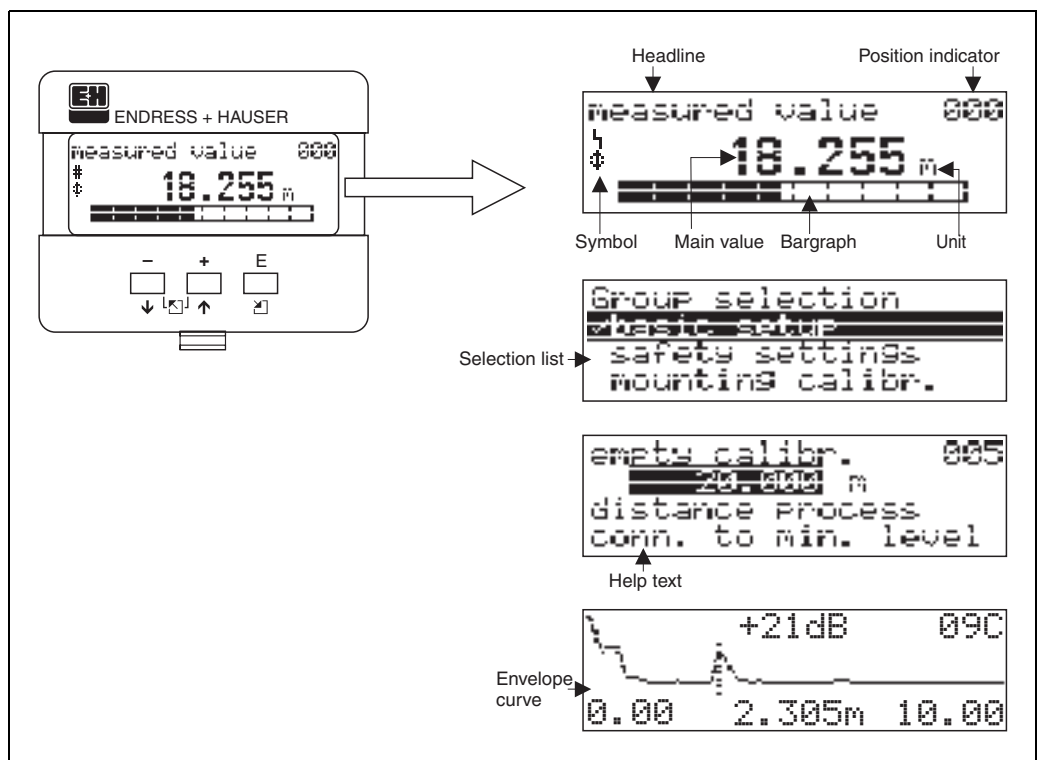





Fig. 3: Display

## 5.2.2 Display symbols















The following table describes the symbols that appear on the liquid crystal display:

| Sybmol  | Meaning   |
|---|---|
|  | <b>ALARM_SYMBOL</b><br>This alarm symbol appears when the instrument is in an alarm state. If the symbol flashes, this indicates a warning.       |
|  | <b>LOCK_SYMBOL</b><br>This lock symbol appears when the instrument is locked, i.e. if no input is possible.                                       |
|  | <b>COM_SYMBOL</b><br>This communication symbol appears when a data transmission via e.g. HART, PFOFIBUS-PA or Foundation Fieldbus is in progress. |

## 5.2.3 Key assignment

The operating elements are located inside the housing and are accessible for operation by opening the lid of the housing.

### Function of the keys

| Key(s)   | Meaning   |
|--|---|
|  or    | Navigate upwards in the selection list<br>Edit numeric value within a function  |
|  or    | Navigate downwards in the selection list<br>Edit numeric value within a function  |
|   or    | Navigate to the left within a function group  |
|   | Navigate to the right within a function group, confirmation.  |
|  and <br>or<br> and  | Contrast settings of the LCD  |
|  and  and   | Hardware lock / unlock<br>After a hardware lock, an operation of the instrument via display or communication is not possible!<br>The hardware can only be unlocked via the display. An unlock parameter must be entered to do so. |



### 5.3 Local operation







#### 5.3.1 Locking of the configuration mode

The Micropilot can be protected in two ways against unauthorised changing of instrument data, numerical values or factory settings:

##### "unlock parameter" (0A4):

A value  $\leftrightarrow$  100 (e.g. 99) must be entered in "unlock parameter" (0A4) in the "diagnostics" (0A) function group. The lock is shown on the display by the  symbol and can be released again either via the display or by communication.

##### Hardware lock:

The instrument is locked by pressing the  and  and  keys at the same time. The lock is shown on the display by the  symbol and can **only** be unlocked again via the display by pressing the ,  and  keys at the same time again. It is **not** possible to unlock the hardware by communication. All parameters can be displayed even if the instrument is locked.

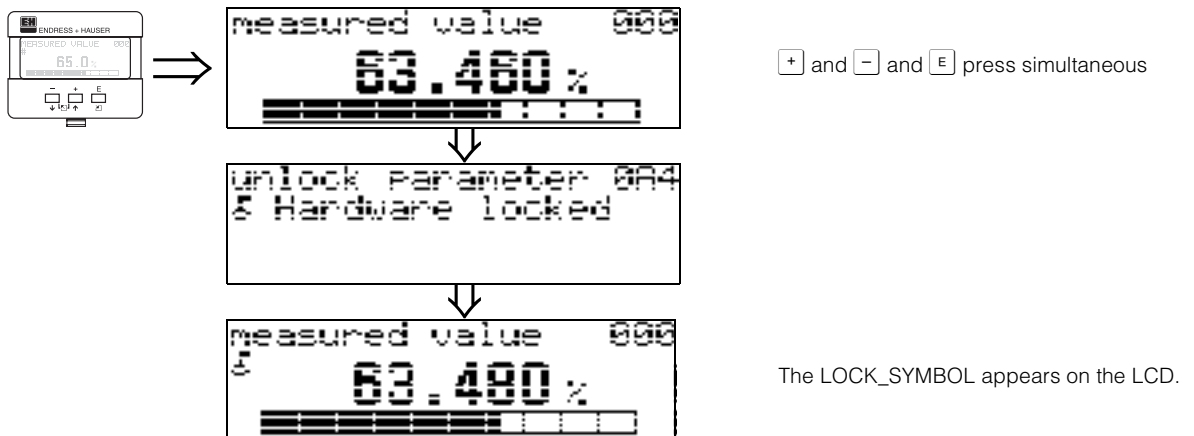

### 5.3.2 Unlocking of configuration mode

If an attempt is made to change parameters on display when the instrument is locked, the user is automatically requested to unlock the instrument:

#### unlock parameter" (0A4):

By entering the unlock parameter (on the display or via communication)

**100** = for HART devices

the Micropilot is released for operation.

#### Hardware unlock:

After pressing the **+** and **-** and **E** keys at the same time, the user is asked to enter the unlock parameter

**100** = for HART devices.

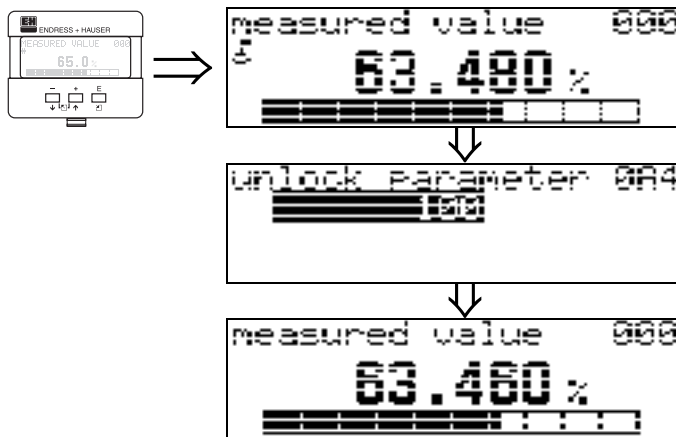

**+** and **-** and **E** press simultaneous

Please enter unlock code and confirm with **E**.



#### Caution!

Changing certain parameters such as all sensor characteristics, for example, influences numerous functions of the entire measuring system, particularly measuring accuracy. There is no need to change these parameters under normal circumstances and consequently, they are protected by a special code known only to the E+H service organization. Please contact Endress+Hauser if you have any questions.

### 5.3.3 Factory settings (Reset)



Caution!

A reset sets the instrument back to the factory settings. This can lead to an impairment of the measurement. Generally, you should perform a basic setup again following a reset.

A reset is only necessary:

- if the instrument no longer functions
- if the instrument must be moved from one measuring point to another
- if the instrument is being de-installed /put into storage/installed

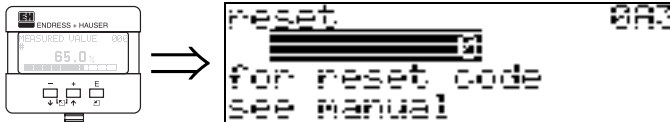

**User input ("reset" (0A3)):**

- 333 = customer parameters

#### **333 = reset customer parameters**

This reset is recommended whenever an instrument with an unknown 'history' is to be used in an application:

- The Micropilot is reset to the default values.
- The customer specific tank map is not deleted.
- A linearisation is switched to "**linear**" although the table values are retained. The table can be reactivated in the "**linearisation**" (04) function group.

List of functions that are affected by a reset:

- |                         |                          |
|-------------------------|--------------------------|
| • tank shape (002)      | • diameter vessel (047)  |
| • empty calibr. (005)   | • range of mapping (052) |
| • full calibr. (006)    | • pres. Map dist (054)   |
| • pipe diameter (007)   | • offset (057)           |
| • output on alarm (010) | • low output limit (062) |
| • output on alarm (011) | • fixed current (063)    |
| • outp. echo loss (012) | • fixed cur. value (064) |
| • ramp %span/min (013)  | • simulation (065)       |
| • delay time (014)      | • simulation value (066) |
| • safety distance (015) | • 4mA value (068)        |
| • in safety dist. (016) | • 20mA value (069)       |
| • level/ullage (040)    | • format display (094)   |
| • linearisation (041)   | • distance unit (0C5)    |
| • customer unit (042)   | • download mode (0C8)    |

The tank map can also be reset in the "**mapping**" (055) function of the "**extended calibr.**" (05) function group.

This reset is recommended whenever an instrument with an unknown 'history' is to be used in an application or if a faulty mapping was started:



- The tank map is deleted. The mapping must be recommenced.

## 5.4 Display and acknowledging error messages

### Types of errors

Errors that occur during commissioning or measuring are displayed immediately on the local display. If two or more system or process errors occur, the error with the highest priority is the one shown on the display.

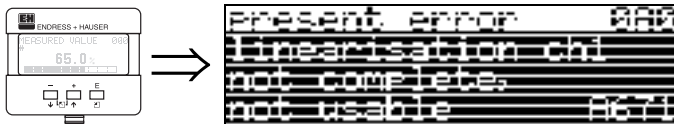

#### The measuring system distinguishes between two types of errors:

- **A (Alarm):**  
Instrument goes into a defined state (e.g. MAX 22 mA)  
Indicated by a constant  symbol.  
(For a description of the codes, see Page 64)
- **W (Warning):**  
Instrument continue measuring, error message is displayed.  
Indicated by a flashing  symbol.  
(For a description of the codes, see Page 64)
- **E (Alarm / Warning):**  
Configurable (e.g. loss of echo, level within the safety distance)  
Indicated by a constant/flashing  symbol.  
(For a description of the codes, see Page 64)



### 5.4.1 Error messages

Error messages appear as four lines of plain text on the display. In addition, a unique error code is also output. A description of the error codes is given on Page 64.

- The "**diagnostics**" (**0A**) function group can display current errors as well as the last errors that occurred.
- If several current errors occur, use  or  to page through the error messages.
- The last occurring error can be deleted in the "**diagnostics**" (**0A**) function group with the funktion "**clear last error**" (**0A2**).

## 5.5 HART communication

Apart from local operation, you can also parameterise the measuring instrument and view measured values by means of a HART protocol. There are two options available for operation:

- Operation via the universal handheld operating unit, the HART Communicator DXR 275.
- Operation via the Personal Computer (PC) using the operating program (e.g. ToF Tool or Commwin II) (For connections, see Page 27).



Note!

The Microplot M can also be operated locally using the keys. If operation is prevented by the keys being locked locally, parameter entry via communication is not possible either.

### 5.5.1 Handheld unit Field Communicator DXR 375

All device functions can be adjusted via menu operation with the handheld unit DXR 375.



Abb. 4: Menu operation with the DXR 375 handheld instrument



Note!

- Further information on the HART handheld unit is given in the respective operating manual included in the transport bag of the instrument.

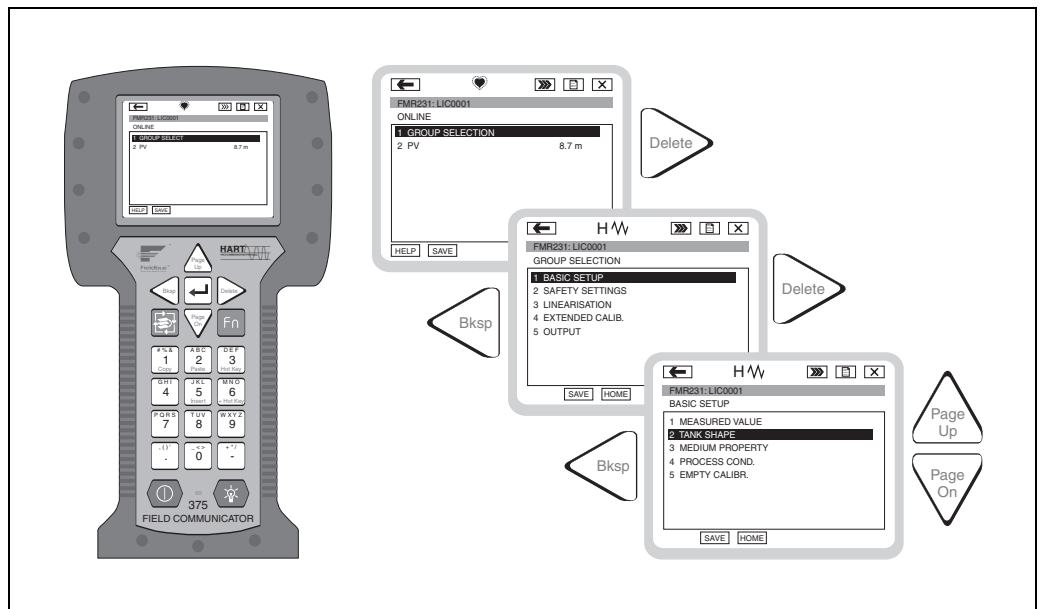
### 5.5.2 ToF Tool operating program

The ToF Tool is a graphical operating software for instruments from Endress+Hauser that operate based on the time-of-flight principle. It is used to support commissioning, securing of data, signal analysis and documentation of the instruments. It is compatible with the following operating systems: Win95, Win98, WinNT4.0 and Win2000.

The ToF Tool supports the following functions:

- Online configuration of transmitters
- Signal analysis via envelope curve
- Tank linearisation
- Loading and saving of instrument data (Upload/Download)
- Documentation of measuring point



Note!  
Further information you may find on the CD-ROM, which is enclosed to the instrument.

### Menu-guided commissioning

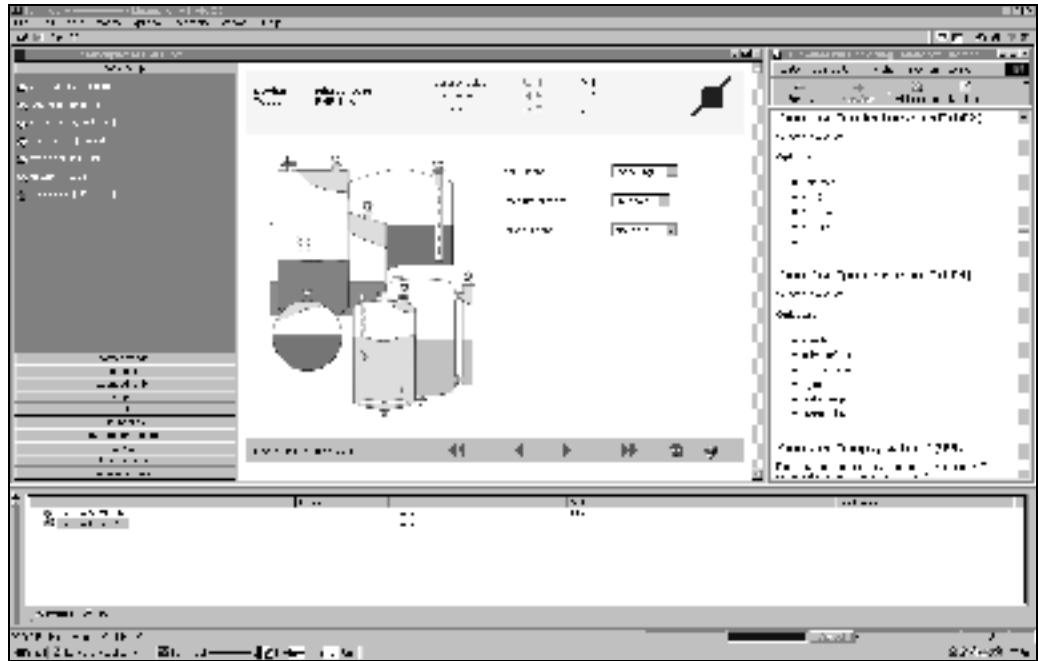

L00-FMR2xxx-20-00-00-en-002

### Signal analysis via envelope curve:

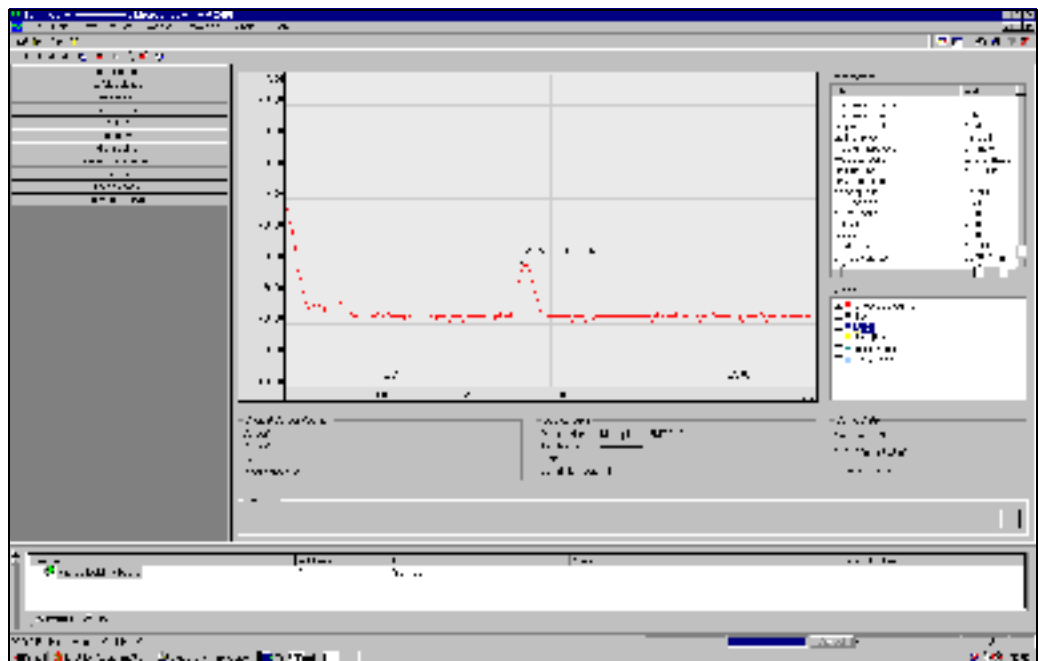

L00-FMR2xxx-20-00-00-en-002

### Connection options

- Service-interface with adapter FXA 193 (see Page 27)
- HART with Commubox FXA 191 (see Page 27)

### 5.5.3 Commuwin II-Operating Programm

Commuwin II is an operating software with graphical support for intelligent transmitters with the communication protocols Rackbus, Rackbus RS 485, INTENSOR, HART or PROFIBUS-PA. It is compatible with the operating systems Win 3.1/3.11, Win95, Win98 and WinNT4.0. All functions of Commuwin II are supported. The configuration is made via operating matrix or graphic surface. An envelope curve can be displayed in ToF Tool.



Note!

Further information on Commuwin II is given in the following E+H documentation:

- System Information: SI 018F/00/en "Commuwin II"
- Operating Manual: BA 124F/00/en "Commuwin II" operating program

#### Connection

The table provides an overview of the Commuwin connections.

| Interface | Hardware  | Server                 | Device list   |
|-----------|---|------------------------|---|
| HART      | Commubox FXA 191 to HART<br>Computer with RS-232C interface               | HART                   | Connected instrument  |
|           | Interface FXN 672<br>Gateway for MODBUS, PROFIBUS,<br>FIP, INTERBUS, etc. | ZA 673 for<br>PROFIBUS | List of all rack bus modules:<br>the required FXN 672 must<br>be selected |
|           | Computer with<br>RS-232C interface or<br>PROFIBUS card                    | ZA 672 for<br>other    |   |

## 6 Commissioning

### 6.1 Function check

Make sure that all final checks have been completed before you start up your measuring point:

- Checklist “Post installation check” (see Page 22).
- Checklist “Post connection check” (see Page 28).

### 6.2 Switching on the measuring device

When the instrument is switched on for the first time, the following messages appear on the display:

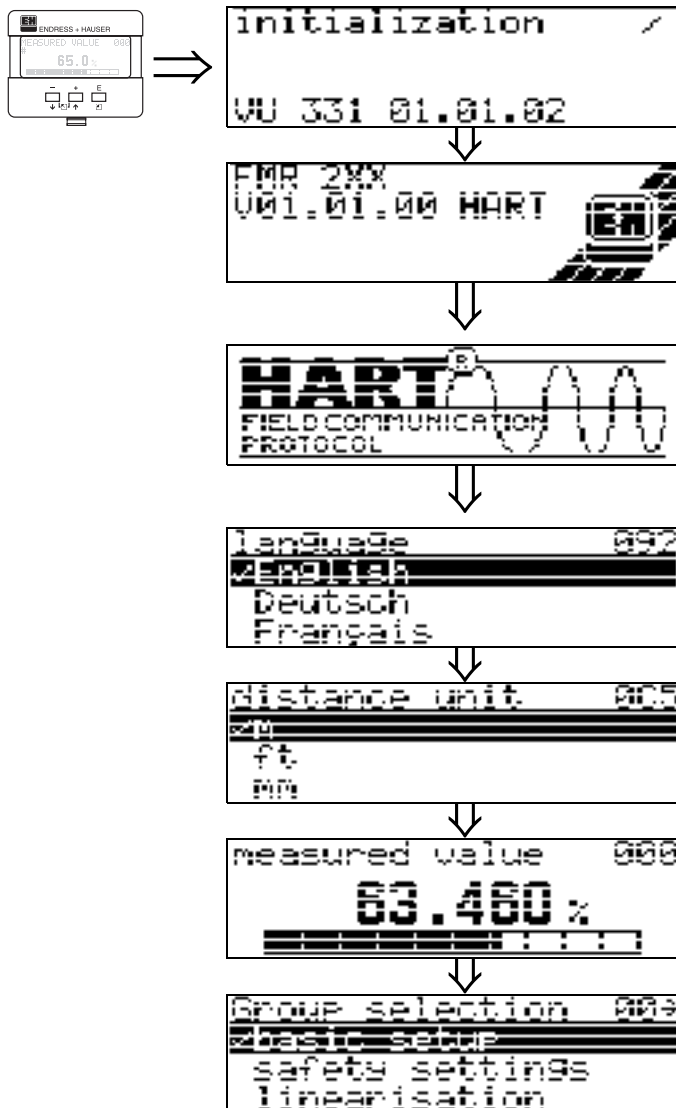

After 5 s, the following message appears

After 5 s, the following message appears (e.g. for HART devices)

After 5 s or after you have pressed **E** the following message appears

Select the language (this message appears the first time the instrument is switched on)

Select the basic unit (this message appears the first time the instrument is switched on)

The current measured value is displayed

After **E** is pressed, you reach the group selection.

This selection enables you to perform the basic setup



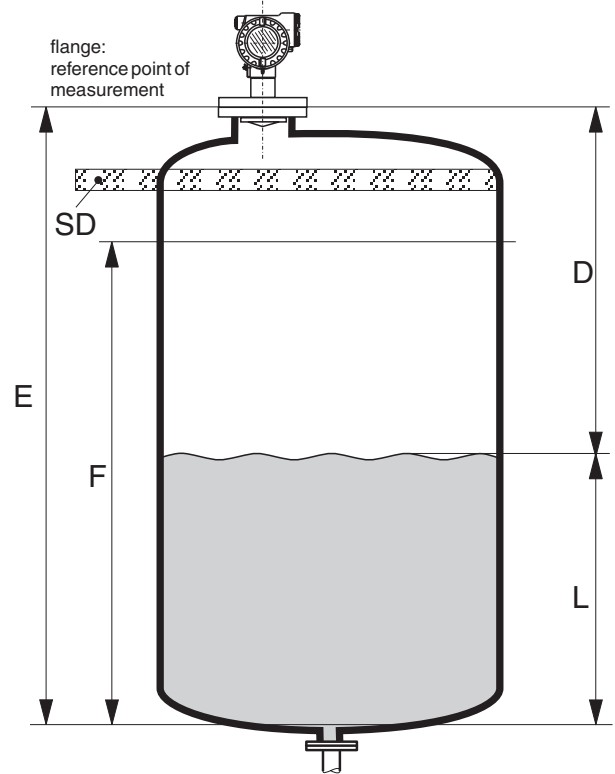
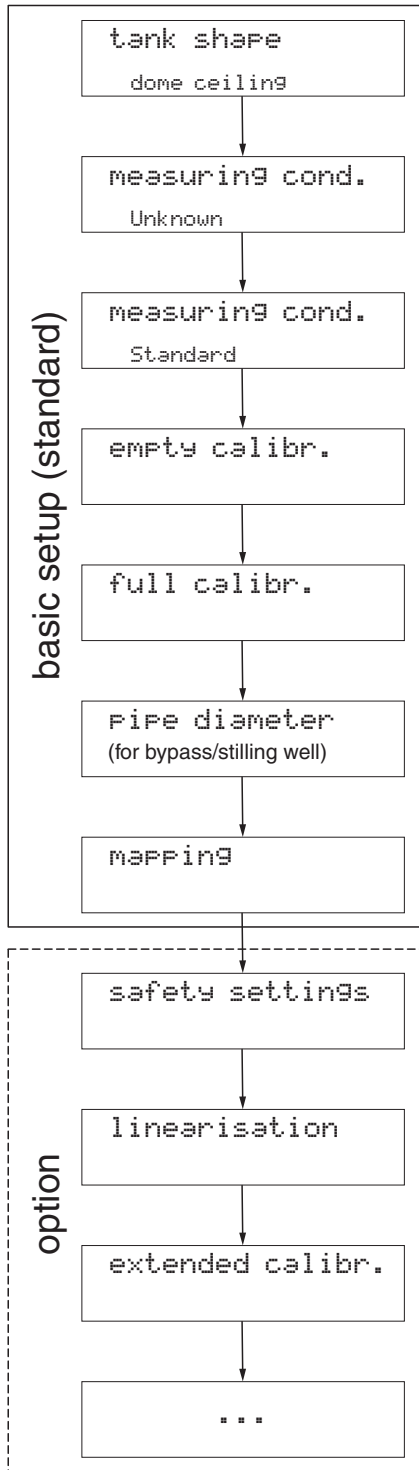

### 6.3 Basic Setup



- E = empty calibr. (= zero)  
setting in 005
- F = full calibr. (= span)  
setting in 006
- D = distance (distance flange / product)  
display in OA5
- L = level  
display in OA6
- SD = safety distance  
setting in 015

The basic setup is sufficient for successful commissioning in most applications. Complex measuring operations necessitate additional functions that the user can use to customise the Micropilot as necessary to suit his specific requirements. The functions available to do this are described in detail in the BA 221F.

Comply with the following instructions when configuring the functions in the "**basic setup**" (00):

- Select the functions as described on Page 29.
- Some functions can only be used depending on the parameterisation of the instrument. For example, the pipe diameter of a stilling well can only be entered if "**stilling well**" was selected beforehand in the "**tank shape**" (002) function.
- Certain functions (e.g. starting an interference echo mapping (053)) prompt you to confirm your data entries. Press  or  to select "**YES**" and press  to confirm. The function is now started.
- If you do not press a key during a configurable time period (→ function group "**display**" (09)), an automatic return is made to the home position (measured value display).



Note!

- The instrument continues to measure while data entry is in progress, i.e. the current measured values are output via the signal outputs in the normal way.
- If the envelope curve mode is active on the display, the measured values are updated in a slower cycle time. Thus, it is advisable to leave the envelope curve mode after the measuring point has been optimised.
- If the power supply fails, all preset and parameterised values remain safely stored in the EEPROM.



Caution!

All functions are described in detail, as is the overview of the operating menu itself, in the manual "**Description of the instrument functions – BA 221F**", which is found on the enclosed CD-ROM.



Note!

The default values of the parameters are typed in **boldface**.

## 6.4 Basic Setup with the VU 331

### Function "measured value" (000)



This function displays the current measured value in the selected unit (see "customer unit" (042) function). The number of digits after decimal point can be selected in the "no.of decimals" (095) function.

### 6.4.1 Function group "basic setup" (00)

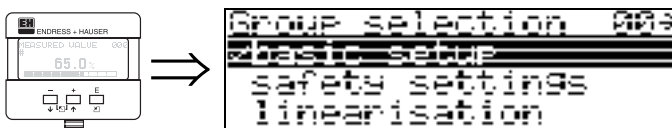

### Function "tank shape" (002)

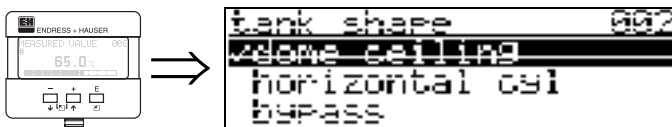

This function is used to select the tank shape.

#### Selection:

- dome ceiling
- horizontal cyl
- bypass
- stilling well, **also for Wave Guide antenna use.**
- flat ceiling
- sphere

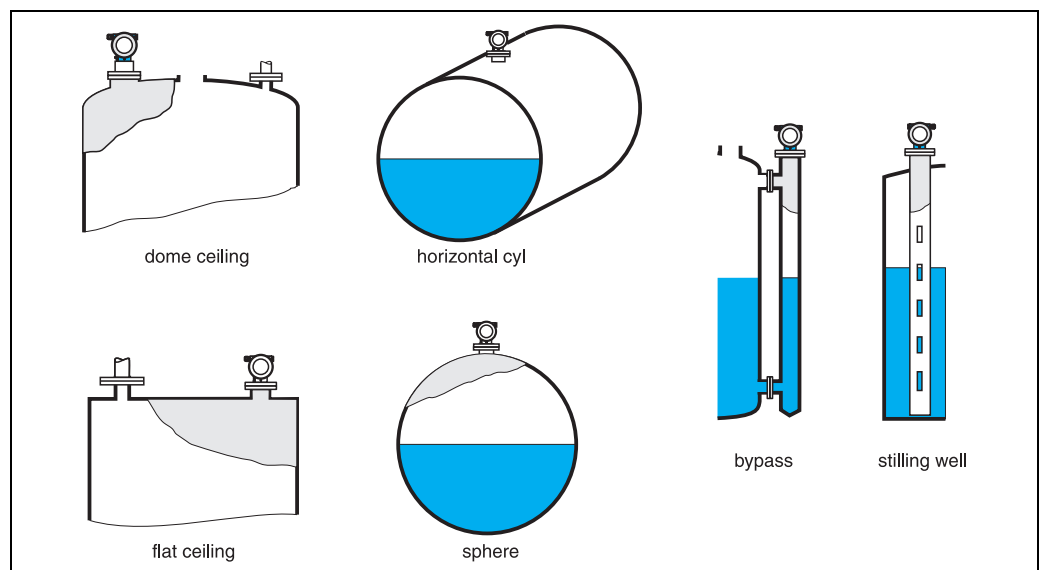

L00-FMR2xxxx-14-00-06-en-007

### Function "medium property" (003)



This function is used to select the dielectric constant.

#### Selection:

- unknown
- DC: < 1.9
- DC: 1.9 ... 4
- DC: 4 ... 10
- DC: > 10

| Product class | DC ( $\epsilon_r$ ) | Examples  |
|---------------|---------------------|---|
| <b>A</b>      | 1,4...1,9           | non-conducting liquids, e.g. liquefied gas <sup>1</sup>                           |
| <b>B</b>      | 1,9...4             | non-conducting liquids, e.g. benzene, oil, toluene, ...                           |
| <b>C</b>      | 4...10              | e.g. concentrated acids, organic solvents, esters, aniline, alcohol, acetone, ... |
| <b>D</b>      | >10                 | conducting liquids, e.g. aqueous solutions, dilute acids and alkalis              |

1) Treat Ammonia NH<sub>3</sub> as a medium of group A, i.e. use FMR 230 in a stilling well.

**Function "process cond." (004)**

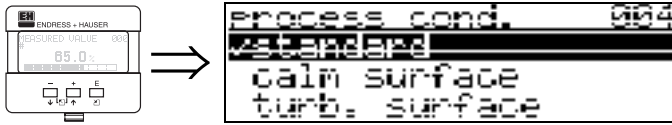

This function is used to select the process conditions.

**Selection:**

- **standard**
- calm surface
- turb. surface
- agitator
- fast change
- test:no filter

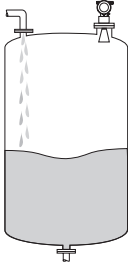
| standard  | calm surface  | turb. surface  |
|---|---|--|
| For all applications that do not fit into any of the following groups.              | Storage tanks with immersion tube or bottom filling   | Storage / buffer tanks with rough surface due to free filling or mixer nozzles                                       |
|  |   |  |
| The filter and output damping are set to average values.                            | The averaging filters and output damping are set to high values.<br>→ steady meas. value<br>→ precise measurement<br>→ slower reaction time | Special filters to smooth the input signals are emphasised.<br>→ smoothed meas. value<br>→ medium fast reaction time |

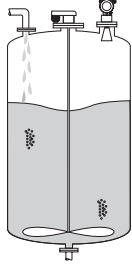
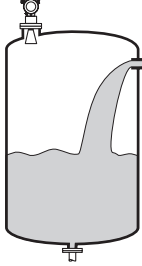
| agitator   | fast change  | test:no filter   |
|--|--|--|
| Agitated surfaces (with possible vortex) due to agitators  | Rapid change of level, particularly in small tanks   | All filters can be switched off for service / diagnostic purposes. |
|   |    |  |
| Special filters to smooth the input signals are set to high values.<br>→ smoothed meas. value<br>→ medium fast reaction time<br>→ minimization of effects by agitator blades | The averaging filters are set to low values. The output damping is set to 0.<br>→ rapid reaction time<br>→ possibly unsteady meas. value | All filters off.   |

**Function "empty calibr." (005)**

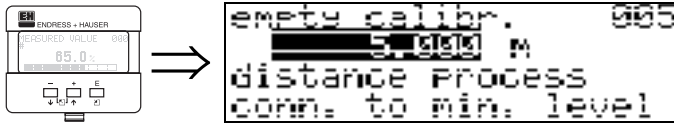

This function is used to enter the distance from the flange (reference point of the measurement) to the minimum level (=zero).

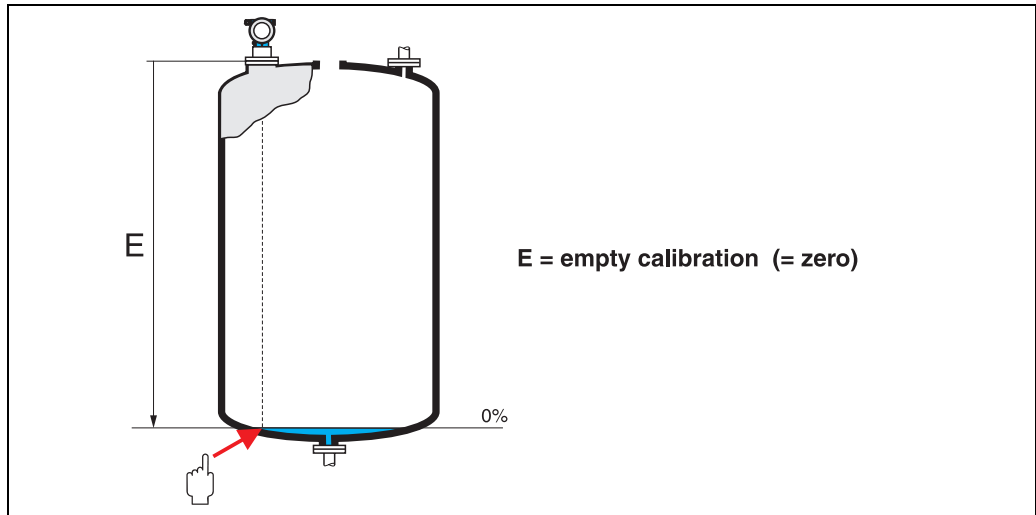

L00-FMR2xxxx-14-00-06-en-008



**Caution!**  
For dish bottoms or conical outlets, the zero point should be no lower than the point at which the radar beam hits the bottom of the tank.

**Function "full calibr." (006)**



This function is used to enter the distance from the minimum level to the maximum level (=span).

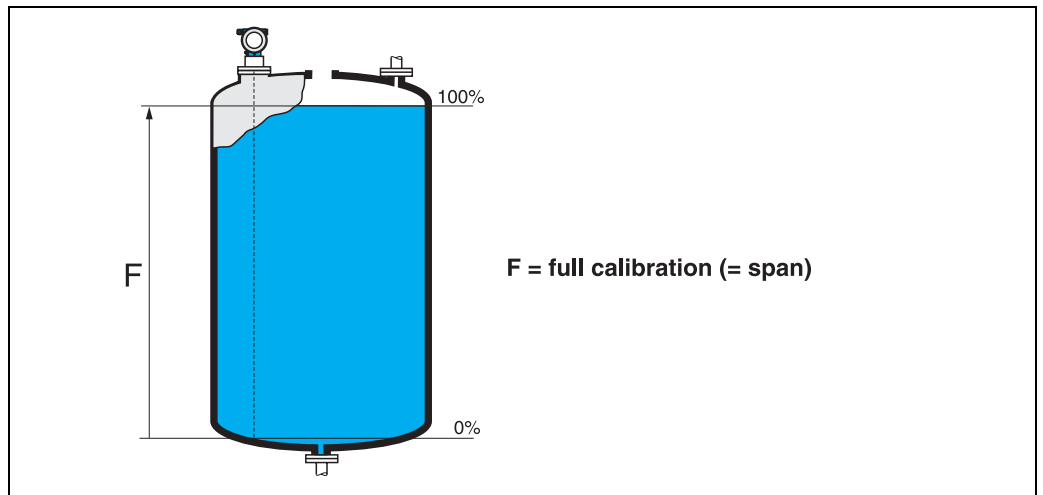

L00-FMR2xxxx-14-00-06-en-009



Note!

If **bypass** or **stilling well** was selected in the "**tank shape**" (002) function, the pipe diameter is requested in the following step.



Note!

For FMR 245, the end of measuring range should not be chosen closer than 200 mm/ 8 inch to the tip of the antenna, especially if there is development of condensate.

### Function "pipe diameter" (007)



This function is used to enter the pipe diameter of the stilling well or bypass pipe.

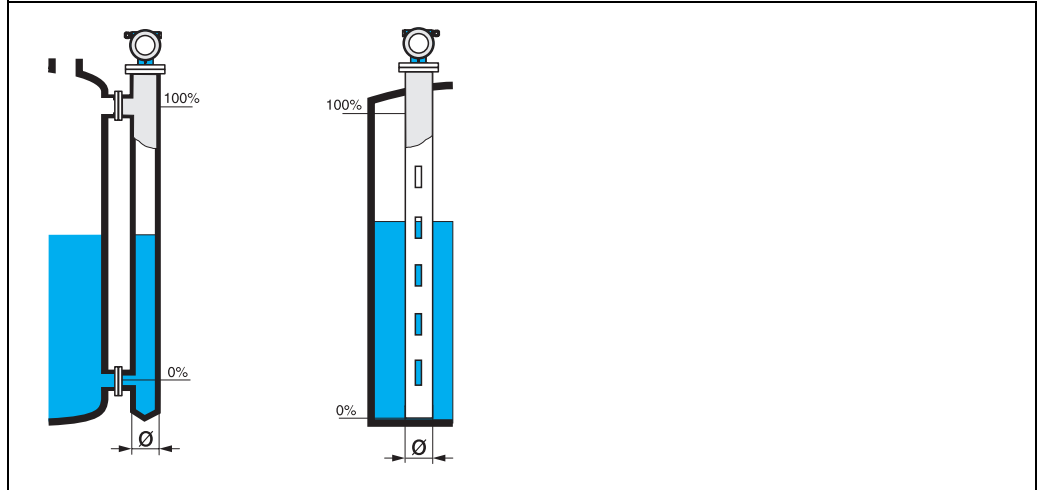

L00-FMR2xxxx-14-00-00-en-011

Microwaves propagate more slowly in pipes than in free space. This effect depends on the inside diameter of the pipe and is automatically taken into account by the Micropilot. It is only necessary to enter the pipe diameter for applications in a bypass or stilling well.



**display (008)**

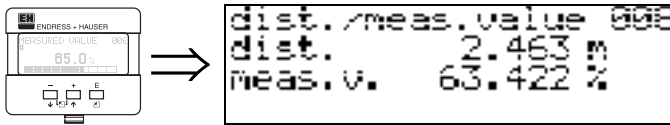

The **distance** measured from the reference point to the product surface and the **level** calculated with the aid of the empty adjustment are displayed. Check whether the values correspond to the actual level or the actual distance. The following cases can occur:

- Distance correct – level correct → continue with the next function, "**check distance**" (051)
- Distance correct – level incorrect → Check "**empty calibr.**" (005)
- Distance incorrect – level incorrect → continue with the next function, "**check distance**" (051)

**Function "check distance" (051)**

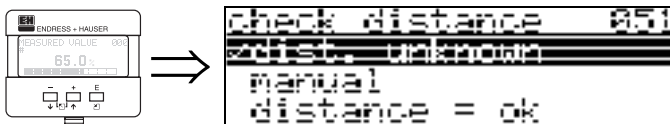

This function triggers the mapping of interference echoes. To do so, the measured distance must be compared with the actual distance to the product surface. The following options are available for selection:

**Selection:**

- distance = ok
- dist. too small
- dist. too big
- **dist. unknown**
- manual

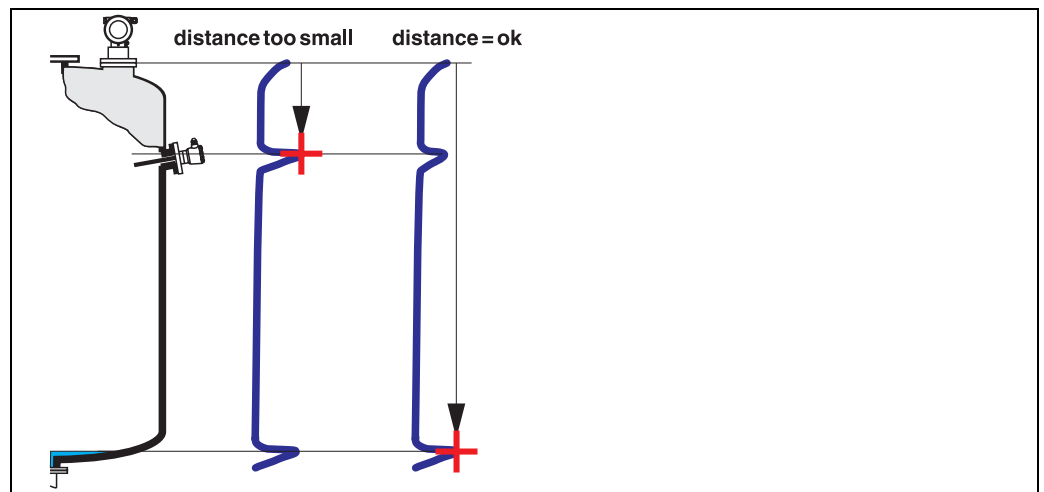

L00\_FMR2xxxx-14-00-06-en-010

**distance = ok**

- mapping is carried out up to the currently measured echo
  - The range to be suppressed is suggested in the "**range of mapping**" (052) function
- Anyway, it is wise to carry out a mapping even in this case.

**dist. too small**

- At the moment, an interference is being evaluated
- Therefore, a mapping is carried out including the presently measured echoes
- The range to be suppressed is suggested in the "**range of mapping**" (052) function

**dist. too big**

- This error cannot be remedied by interference echo mapping
- Check the application parameters (002), (003), (004) and "**empty calibr.**" (005)

**dist. unknown**

If the actual distance is not known, no mapping can be carried out.

**manual**

A mapping is also possible by manual entry of the range to be suppressed. This entry is made in the "**range of mapping**" (052) function.



Caution!

The range of mapping must end 0.5 m (20") before the echo of the actual level. For an empty tank, do not enter E, but E – 0.5 m (20").

If a mapping already exists, it is overwritten up to the distance specified in "**range of mapping**" (052). Beyond this value the existing mapping remains unchanged.

**Function "range of mapping" (052)**

This function displays the suggested range of mapping. The reference point is always the reference point of the measurement (see Page 41). This value can be edited by the operator.

For manual mapping, the default value is 0 m.

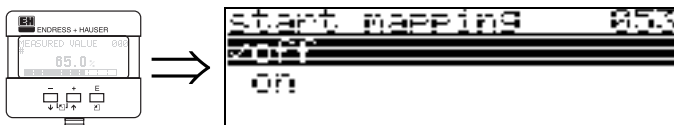
**Function "start mapping" (053)**

This function is used to start the interference echo mapping up to the distance given in "**range of mapping**" (052).

**Selection:**

- off → no mapping is carried out
- on → mapping is started

During the mapping process the message "**record mapping**" is displayed.



Caution!

A mapping will be recorded only, if the device is not in alarm-state.

**display (008)**

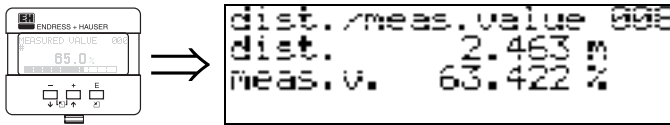

The **distance** measured from the reference point to the product surface and the **level** calculated with the aid of the empty adjustment are displayed. Check whether the values correspond to the actual level or the actual distance. The following cases can occur:

- Distance correct – level correct → continue with the next function, "**check distance**" (051)
- Distance correct – level incorrect → Check "**empty calibr.**" (005)
- Distance incorrect – level incorrect → continue with the next function, "**check distance**" (051)

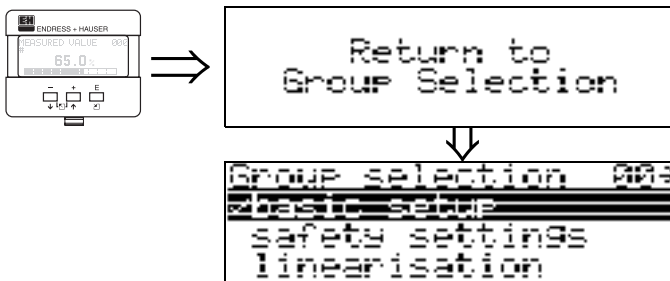

After 3 s, the following message appears

## 6.4.2 Envelope curve with VU 331

After the basic setup, an evaluation of the measurement with the aid of the envelope curve ("envelope curve" (0E) function group) is recommended.

### Function "plot settings" (0E1)



Select which information will be displayed in the LCD:

- **envelope curve**
- env.curve+FAC (on FAC see BA 221F)
- env.curve+cust.map (i.e. customer tank map is also displayed)

### Function "recording curve" (0E2)

This function defines whether the envelope curve is read as a

- **single curve**  
or
- cyclic.



Note!

If the cyclical envelope curve is active in the display, the measured value is refreshed in a slower cycle time. It is therefore recommended to exit the envelope curve display after optimising the measuring point.



Note!

An **orientation** of the Micropilot can help to optimise measurement in applications with very weak level echos or strong interference echos by increasing the useful echo/ reducing the interference echo (see "Orientation of the Micropilot" on Page 68). When using the Wave Guide antenna **no** orientation is required!

### Function "envelope curve display" (0E3)

The envelope curve is displayed in this function. You can use it to obtain the following information:

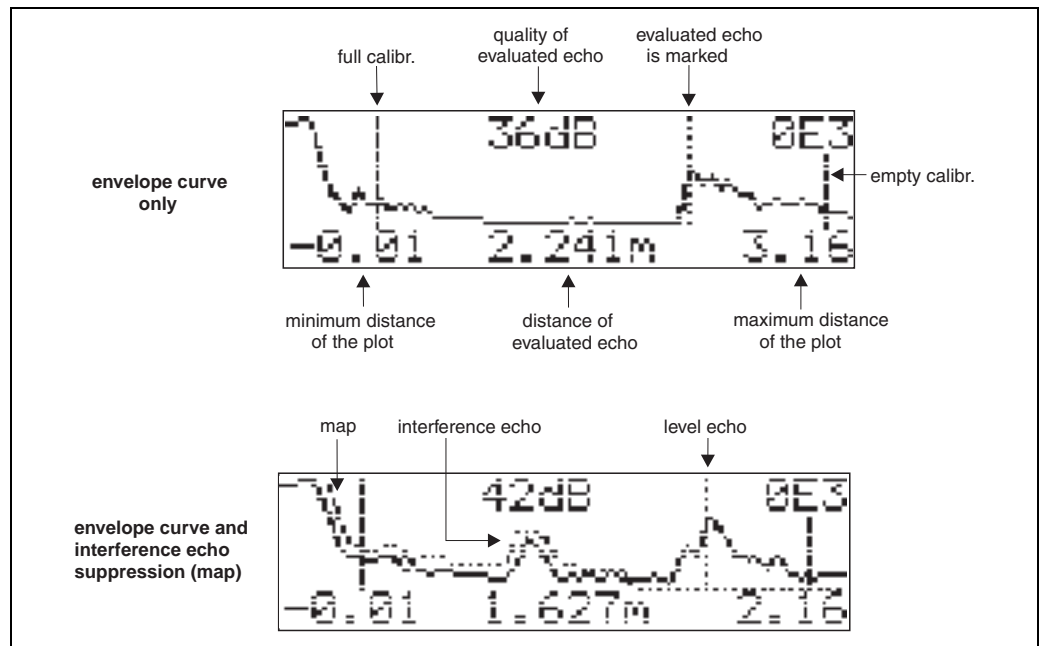

### Navigating in the envelope curve display

Using navigation, the envelope curve can be scaled horizontally and vertically and shifted to the left or the right. The active navigation mode is indicated by a symbol in the top left hand corner of the display.

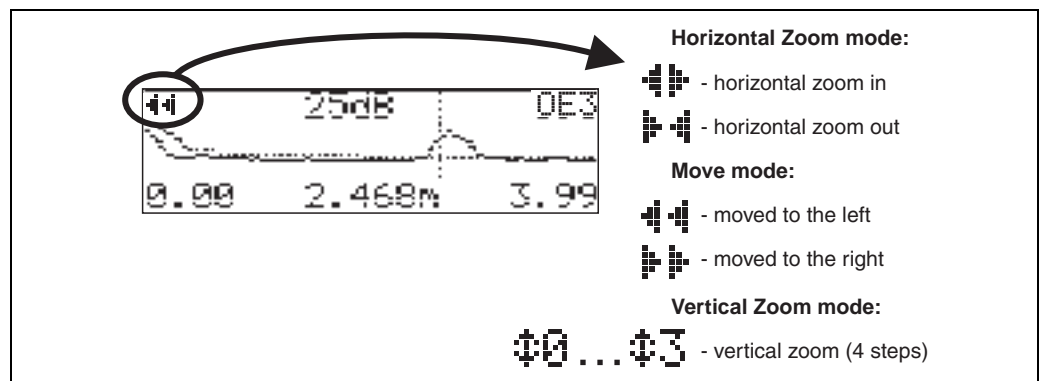

### Horizontal Zoom mode

Firstly, go into the envelope curve display. Then press **+** or **-** to switch to the envelope curve navigation. You are then in Horizontal Zoom mode. Either **+** or **-** is displayed.

- **+** increases the horizontal scale.
- **-** reduces the horizontal scale.

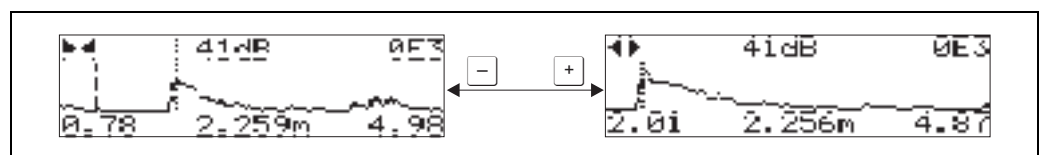

**Move mode**

Then press **[E]** to switch to Move mode. Either **←→** or **↔** is displayed.

- **+** shifts the curve to the right.
- **-** shifts the curve to the left.

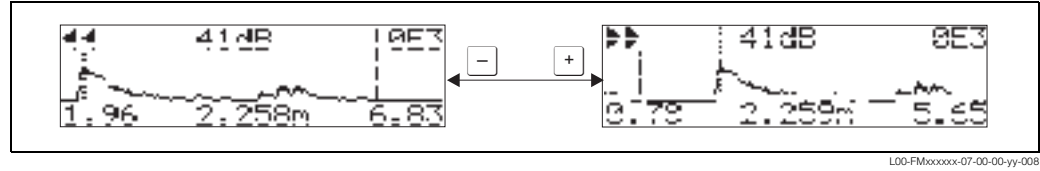

L00-FMxxxxxx-07-00-00-yy-008

**Vertical Zoom mode**

Press **[E]** once more to switch to Vertical Zoom mode. **01** is displayed. You now have the following options.

- **+** increases the vertical scale.
- **-** reduces the vertical scale.

The display icon shows the current zoom factor (**00** to **03**).

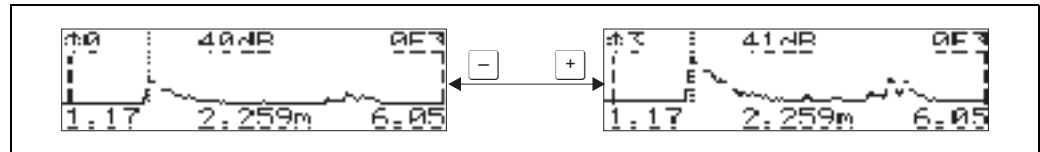

L00-FMxxxxxx-07-00-00-yy-009

**Exiting the navigation**

- Press **[E]** again to run through the different modes of the envelope curve navigation.
- Press **+** and **-** to exit the navigation. The set increases and shifts are retained. Only when you reactivate the "recording curve" (**0E2**) function does the Micropilot use the standard display again.

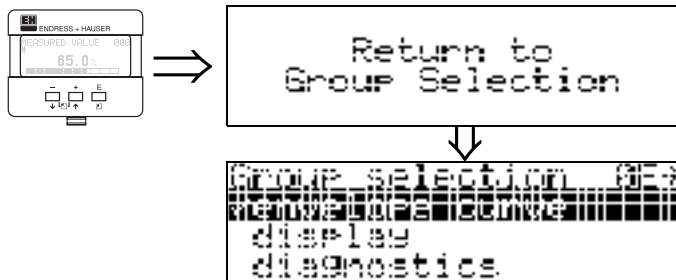

After 3 s, the following message appears

## 6.5 Basic Setup with the ToF Tool

To carry out the basic setup with the ToF Tool operating program, proceed as follows:

- Start the ToF Tool operating program and establish a connection
- Select the "**basic setup**" function group in the navigation bar

The following display appears on the screen:

### Basic Setup step 1/4:

- Status image
- Enter the measuring point description (TAG number).

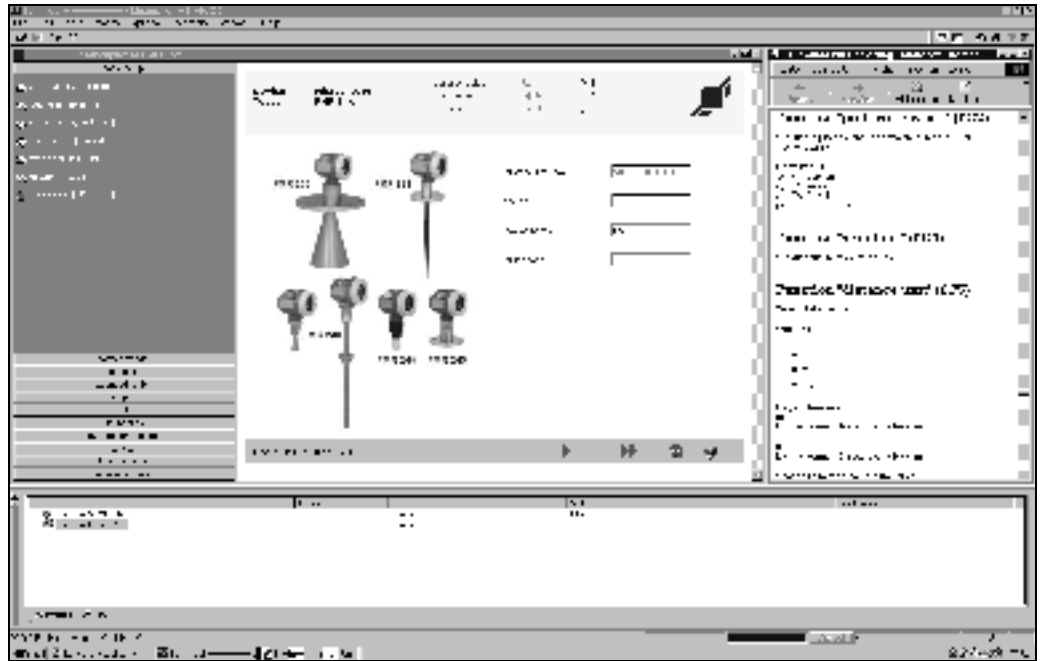

L00-FMR2xxxx-20-00-00-en-001



Note!

- Each parameter that is changed must be confirmed with the **RETURN** key!
- The "**Next**" button moves you to the next screen display:

**Basic Setup step 2/4:**

- Enter the application parameters:
  - tank shape (for a description, see Page 43)
  - medium property (for a description, see Page 44)
  - process cond. (for a description, see Page 45)

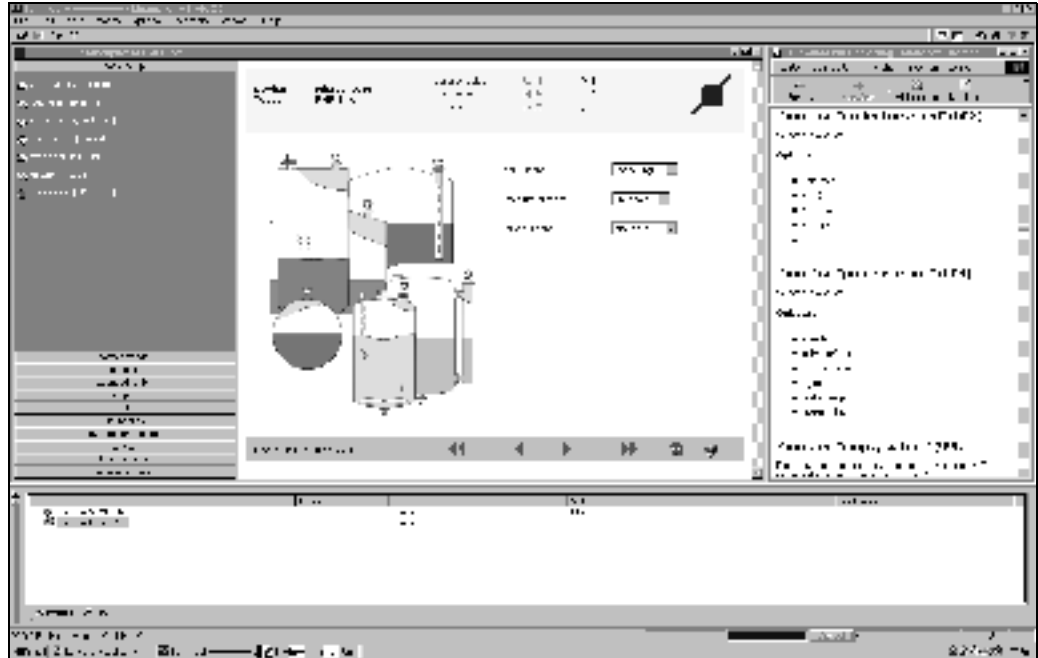

L00-FMR2xxx-20-00-00-en-002

**Basic Setup step 3/4:**

If "**dome ceiling**" is selected in the "**tank shape**" function, the following display appears on the screen:

- empty calibr. (for a description, see Page 46)
- full calibr. (for a description, see Page 47)

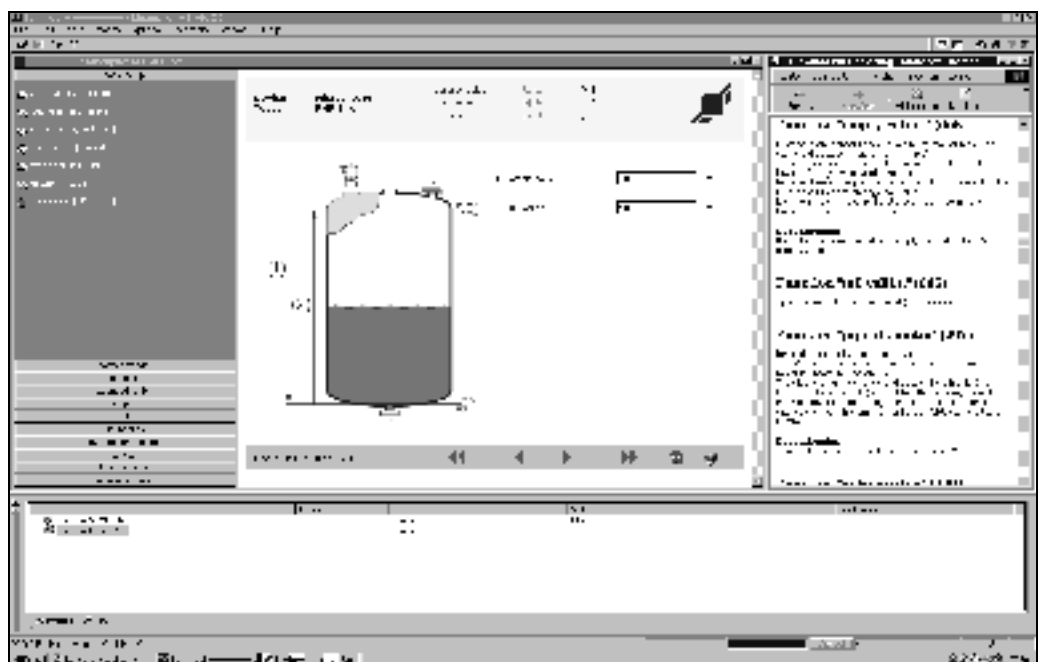

L00-FMR2xxx-20-00-00-en-003



If "**horizontal cyl**" or "**sphere**" is selected in the "**tank shape**" function, the following display appears on the screen:

- empty calibr. (for a description, see Page 46)
- full calibr.(for a description, see Page 47)

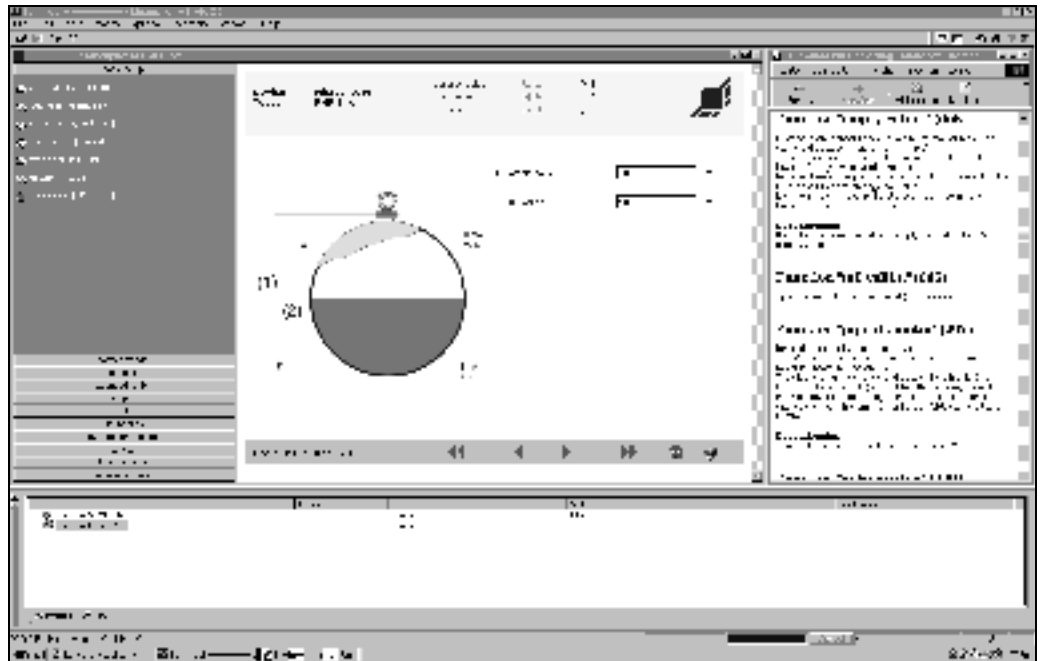

L00-FMR2xxxx-20-00-00-en-004

If "**stilling well**" or "**bypass**" is selected in the "**tank shape**" function, the following display appears on the screen:

- empty calibr. (for a description, see Page 46)
- full calibr.(for a description, see Page 47)
- diameter of bypass / stilling well (for a description, see Page 48)



L00-FMR2xxxx-20-00-00-en-005



Note!  
You can also specify the pipe diameter in this display.

If **"flat ceiling"** is selected in the **"tank shape"** function, the following display appears on the screen:

- empty calibr. (for a description, see Page 46)
- full calibr. (for a description, see Page 47)

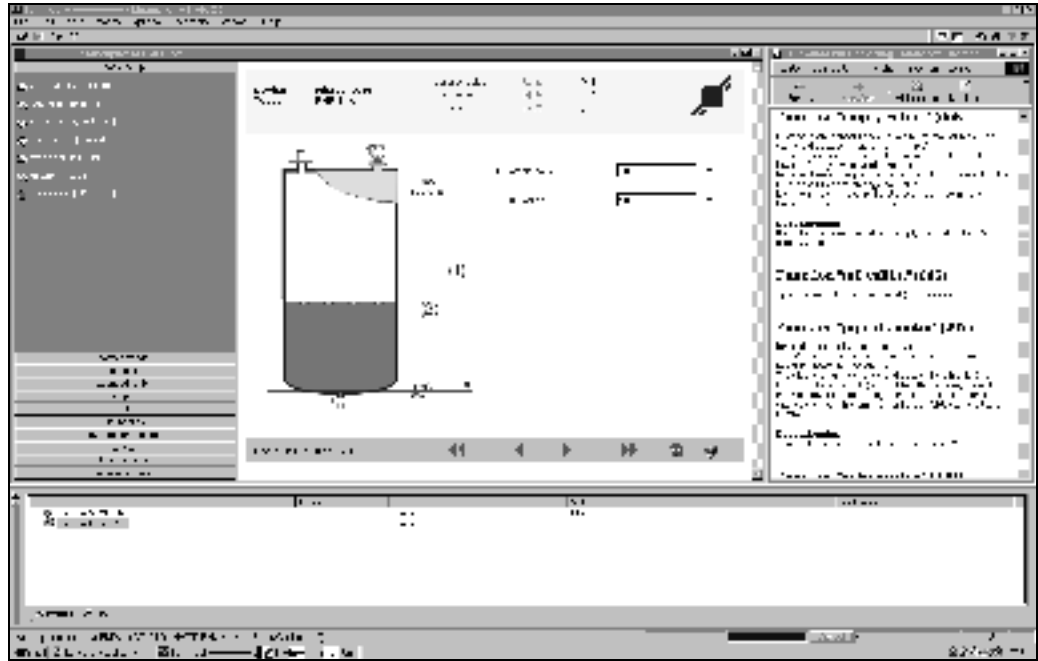

#### Basic Setup step 4/4:

- This step starts the tank mapping
- The measured distance and the current measured value are always displayed in the header
- A description is given on Page 49

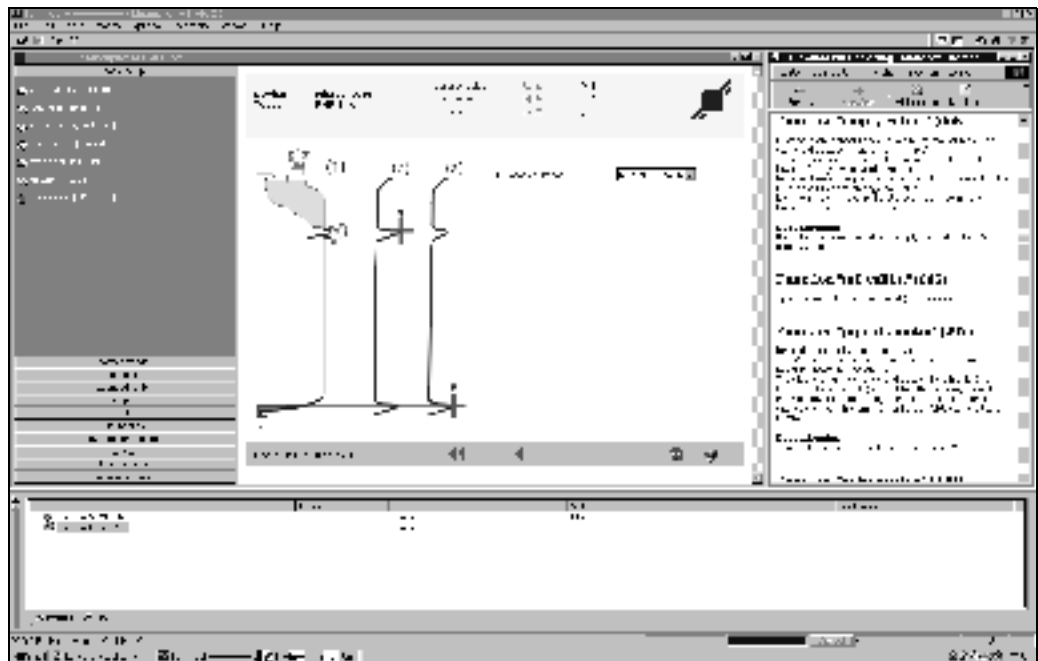

### 6.5.1 Envelope curve with the ToF Tool

After the basic setup, an evaluation of the measurement using the envelope curve is recommended.

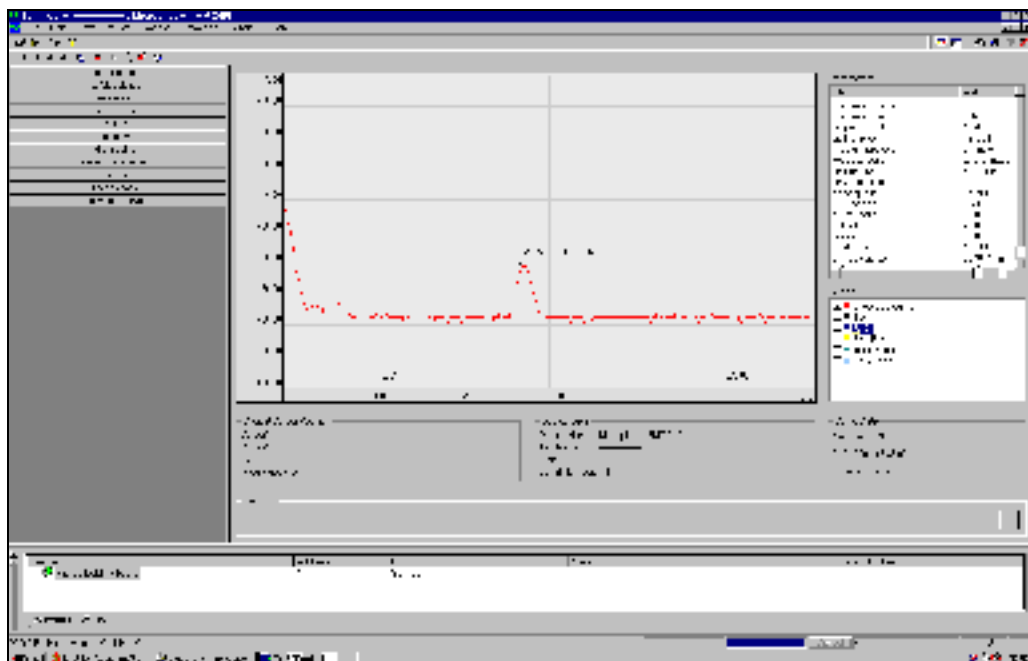

L00-FMR2xxxx-20-00--00-en-008



#### Note!

If the level of echo is very weak or there is a heavy interference echo, an orientation of the Micropilot can help optimise the measurement (increase of the useful echo/reduction of the interference echo) (see "Orientation of the Micropilot" on Page 68). When using the Wave Guide antenna: **No** orientation is required!

### 6.5.2 User-specific applications (operation)

For details of setting the parameters of user-specific applications, see separate documentation BA 221F/00/en "Description of the instrument functions for Micropilot M" on the enclosed CD-ROM.

## 7 Maintenance

The Micropilot M measuring instrument requires no special maintenance.

### Exterior cleaning

When cleaning the exterior of measuring devices, always use cleaning agents that do not attack the surface of the housing and the seals.

### Replacing seals

The process seals of the sensors must be replaced periodically, particularly if molded seals (aseptic construction) are used. The period between changes depends on the frequency of cleaning cycles and on the temperature of the measured substance and the cleaning temperature.

### Repairs

The Endress+Hauser repair concept assumes that the measuring devices have a modular design and that customers are able to undertake repairs themselves. Spare parts are contained in suitable kits. They contain the related replacement instructions. All the spare parts kits which you can order from Endress+Hauser for repairs to the Micropilot M are listed with their order numbers on [and](#) [. Please contact Endress+Hauser Service for further information on service and spare parts.](#)

### Repairs to Ex-approved devices

When carrying out repairs to Ex-approved devices, please note the following:

- Repairs to Ex-approved devices may only be carried out by trained personnel or by Endress+Hauser Service.
- Comply with the prevailing standards, national Ex-area regulations, safety instructions (XA) and certificates.
- Only use original spare parts from Endress+Hauser.
- When ordering a spare part, please note the device designation on the nameplate. Only replace parts with identical parts.
- Carry out repairs according to the instructions. On completion of repairs, carry out the specified routine test on the device.
- Only Endress+Hauser Service may convert a certified device into a different certified variant.
- Document all repair work and conversions.

### Replacement

After a complete Micropilot or electronic module has been replaced, the parameters can be downloaded into the instrument again via the communication interface. Prerequisite to this is that the data were uploaded to the PC beforehand using the ToF Tool / Commuwin II.

Measurement can continue without having to carry out a new setup.

- You may have to activate linearisation (see BA 221F on the enclosed CD-ROM)
- You may need to record the tank map again (see Basic Setup)

After an antenna component or electronic has been replaced, a new calibration must be carried out. This is described in the repair instructions.

## 8 Accessories

Various accessories, which can be ordered separately from Endress+Hauser, are available for the Micropilot M.

### Weather protection cover

A Weather protection cover made of stainless steel is available for outdoor mounting (order code: 543199-0001). The shipment includes the protective cover and tension clamp.

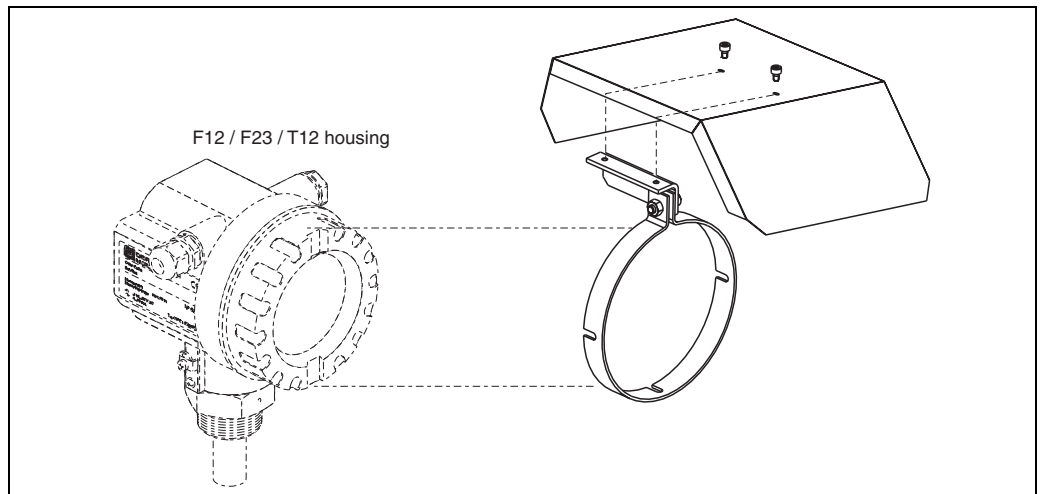

### Commubox FXA 191 HART

For intrinsically safe communication with ToF Tool or Commuwin II via the RS 232C-interface.

### Service Interface FXA 193

For communication with ToF Tool via the display connector.

Ordering structure:

- FXA 193-A: for use in non-hazardous area
- FXA 193-B: for use in hazardous area (ATEX, CSA, FM)

The connection to a ToF device needs an additional FXA connection cable (order code.: 50101787).

### Commuwin II

Operating software for intelligent instruments.

**Remote display FHX 40**

*Dimensions*

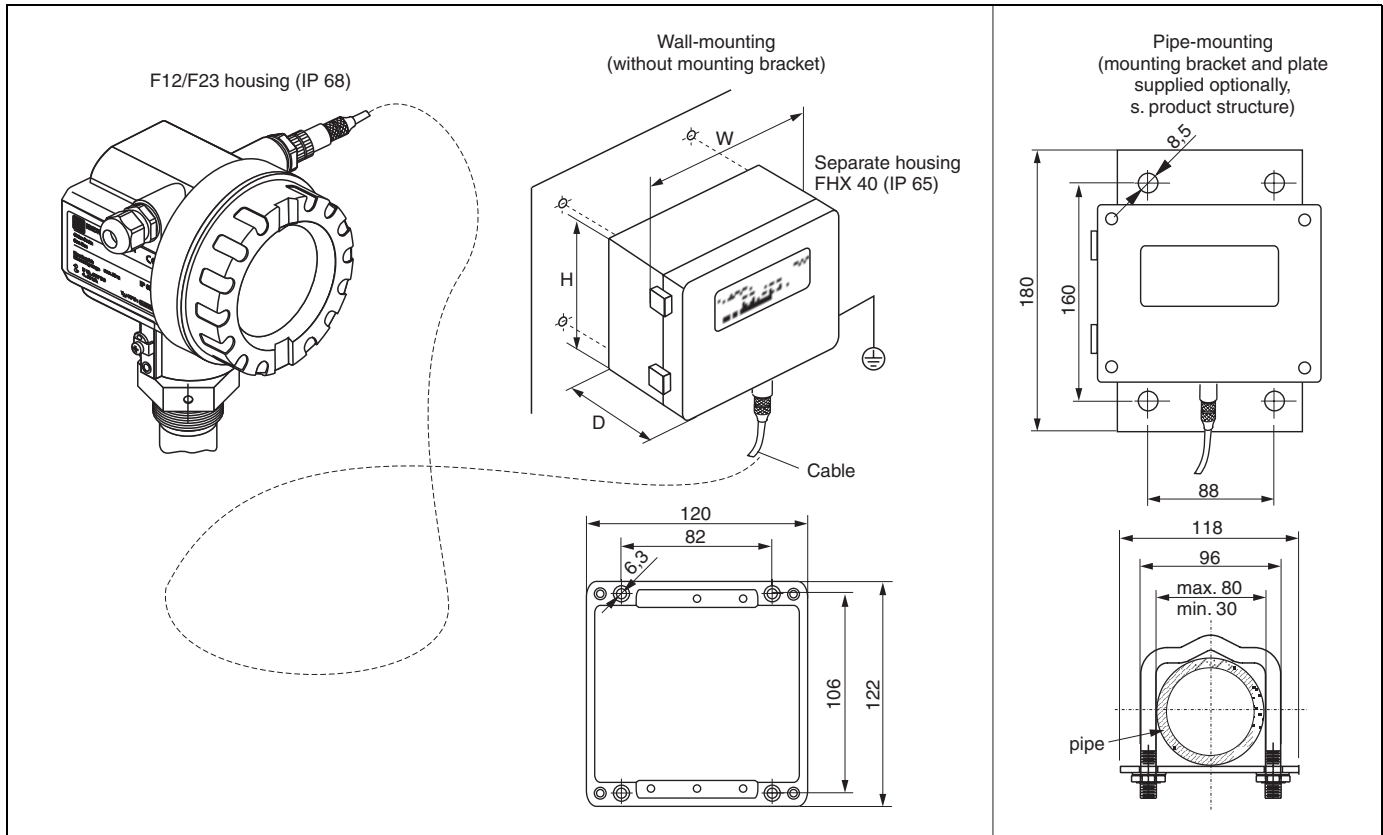

*Technical data:*

|                          |                                   |
|--------------------------|-----------------------------------|
| Max. cable length        | 20 m (65 ft)                      |
| Temperature range        | -30 °C...+70 °C (-22 °F...158 °F) |
| Degree of protection     | IP65 acc. to EN 60529 (NEMA 4)    |
| Material for housing     | Alloy of Aluminium AL Si 12       |
| Dimensions [mm] / [inch] | 122x150x80 (HxBxT) / 4.8x5.9x3.2  |

*Ordering structure*

| Certificates      |  |
|-------------------|--|
| A                 | For non-hazardous area                 |
| 1                 | ATEX II 2 G EEx ia IIC T6, ATEX II 3D  |
| S                 | FM IS Class I Div. 1, Groups A,B,C,D   |
| U                 | CSA IS Class I, Div. 1, Groups A,B,C,D |
| N                 | CSA General Purpose (in preparation)   |
| Cable length      |  |
| 1                 | 20 m cable                             |
| Additional option |  |
| A                 | Additional option not selected         |
| B                 | Mounting bracket 1" or 2" pipe         |
| <b>FHX 40 -</b>   | Complete product designation           |

# 9 Trouble-shooting

## 9.1 Trouble-shooting instructions

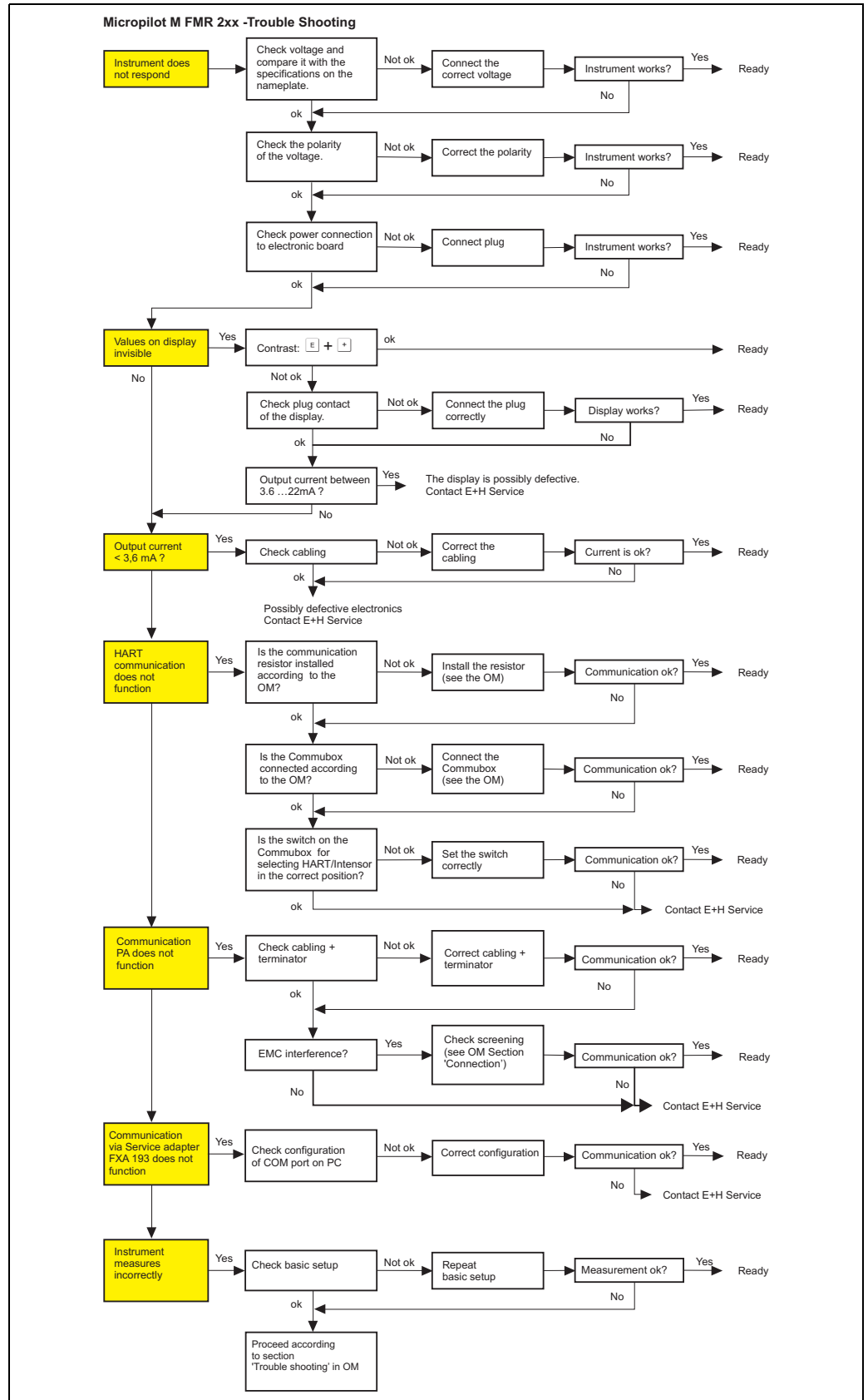

L00-FMR2xxxx-19-00-00-en-010

## 9.2 System error messages

| Code | Description  | Possible cause  | Remedy   |
|------|--|---|--|
| A102 | checksum error<br>general reset & new<br>calibr.required | device has been powered off before<br>data could be stored;<br>emc problem;<br>E <sup>2</sup> PROM defect | reset;<br>avoid emc problem;<br>if alarm prevails after reset,<br>exchange electronics |
| W103 | initialising - please wait                               | E <sup>2</sup> PROM storage not yet finished  | wait some seconds; if warning<br>prevails, exchange electronics                        |
| A106 | downloading please<br>wait                               | processing data download  | wait until warning disappears  |
| A110 | checksum error<br>general reset & new<br>calibr.required | device has been powered off before<br>data could be stored;<br>emc problem;<br>E <sup>2</sup> PROM defect | reset;<br>avoid emc problem;<br>if alarm prevails after reset,<br>exchange electronics |
| A111 | electronics defect                                       | RAM defective   | reset;<br>if alarm prevails after reset,<br>exchange electronics                       |
| A113 | electronics defect                                       | RAM defective   | reset;<br>if alarm prevails after reset,<br>exchange electronics                       |
| A114 | electronics defect                                       | E <sup>2</sup> PROM defect  | reset;<br>if alarm prevails after reset,<br>exchange electronics                       |
| A115 | electronics defect                                       | general hardware problem  | reset;<br>if alarm prevails after reset,<br>exchange electronics                       |
| A116 | download error<br>repeat download                        | checksum of stored data not correct   | restart download of data   |
| A121 | electronics defect                                       | no factory calibration existant;<br>EPROM defective   | contact service  |
| W153 | initialising - please wait                               | initialisation of electronics   | wait some seconds; if warning<br>prevails, power off device and<br>power on again      |
| A155 | electronics defect                                       | hardware problem  | reset;<br>if alarm prevails after reset,<br>exchange electronics                       |
| A160 | checksum error<br>general reset & new<br>calibr.required | device has been powered off before<br>data could be stored;<br>emc problem;<br>E <sup>2</sup> PROM defect | reset;<br>avoid emc problem;<br>if alarm prevails after reset,<br>exchange electronics |
| A164 | electronics defect                                       | hardware problem  | reset;<br>if alarm prevails after reset,<br>exchange electronics                       |
| A171 | electronics defect                                       | hardware problem  | reset;<br>if alarm prevails after reset,<br>exchange electronics                       |
| A231 | sensor 1 defect<br>check connection                      | HF module or electronics defective  | exchange HF module or<br>electronics   |
| W511 | no factory calibration<br>ch1                            | factory calibration has been deleted  | record new factory calibration   |
| A512 | recording of mapping<br>please wait                      | mapping active  | wait some seconds until alarm<br>disappears  |
| A601 | linearisation ch1 curve<br>not monotone                  | linearisation not monotonously<br>increasing  | correct linearisation table  |
| W611 | less than 2 linearisation<br>points for channel 1        | number of entered linearisation<br>points < 2   | correct linearisation table  |



| <b>Code</b> | <b>Description</b>                           | <b>Possible cause</b>  | <b>Remedy</b>   |
|-------------|--|--|---|
| W621        | simulation ch. 1 on                          | simulation mode is active                                      | switch off simulation mode  |
| E641        | no usable echo channel 1<br>check calibr.    | echo lost due to application conditions or built up on antenna | check installation;<br>optimize orientation of antenna;<br>clean antenna (cf. OM) |
| E651        | level in safety distance - risk of overspill | level in safety distance                                       | alarm will disappear as soon as level leaves safety distance;                     |
| E671        | linearisation ch1 not complete, not usable   | linearisation table is in edit mode                            | activate linearisation table  |
| W681        | current ch1 out of range                     | current out of range (3.8 mA...21.5 mA)                        | check calibration and linearisation   |

### 9.3 Application errors

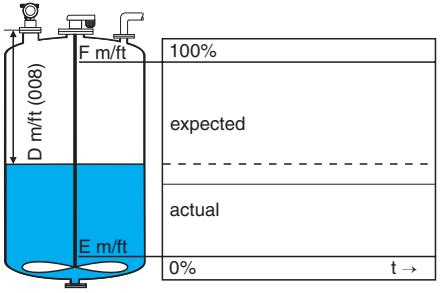
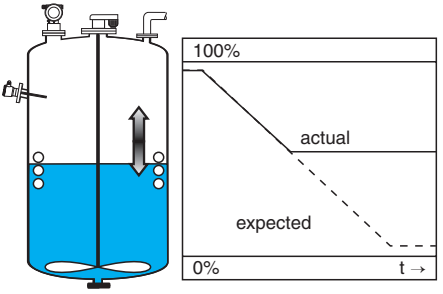
| Error  | Output   | Possible cause   | Remedy   |
|--|--|--|--|
| <p><b>A warning or alarm has occurred.</b></p>                 | <p>Depending on the configuration</p>  | <p>See table of error messages (see Page 64)</p>   | <p>1. See table of error messages (see Page 64)</p>  |
| <p><b>Measured value (00) is incorrect</b></p>                 |  <p style="text-align: right; font-size: small;">L00-FMR2xxxx-19-00-00-en-019</p>   | <p>Measured distance (008) OK?    yes →</p> <p style="text-align: center;">no ↓</p> <p>Measurement in bypass or stilling well?    yes →</p> <p style="text-align: center;">no ↓</p> <p>Is an offset (057) active?    yes →</p> <p style="text-align: center;">no ↓</p> <p>An interference echo may have been evaluated.    yes →</p> | <p>1. Check empty calibr. (005) and full calibr. (006).</p> <p>2. Check linearisation:<br/>                     → level/ullage (040)<br/>                     → max. scale (046)<br/>                     → diameter vessel (047)<br/>                     → Check table</p> <p>1. Is bypass or stilling well selected in tank shape (002)?</p> <p>2. Is the pipe diameter (007) correct?</p> <p>1. offset (057) correctly set?</p> <p>1. Carry out tank mapping → basic setup</p> |
| <p><b>No change off measured value on filling/emptying</b></p> |  <p style="text-align: right; font-size: small;">L00-FMR2xxxx-19-00-00-en-014</p> | <p>Interference echo from installations, nozzle or extension on the antenna</p>  | <p>1. Carry out tank mapping → basic setup</p> <p>2. If necessary, clean antenna</p> <p>3. If necessary, select better mounting position (see Page 13)</p>   |

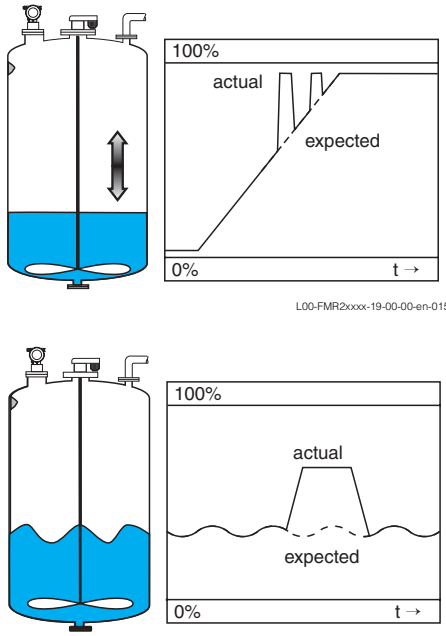
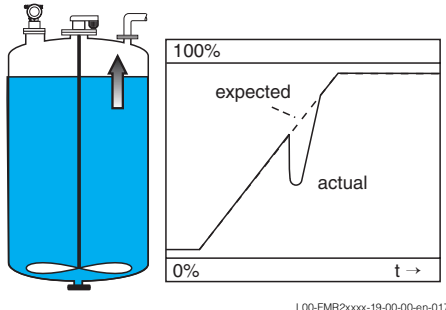
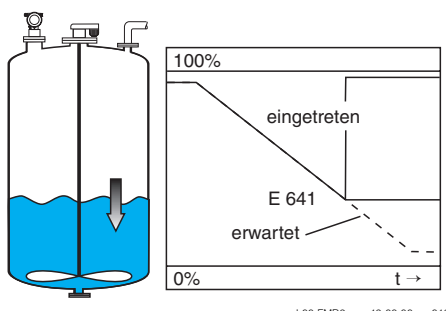
| Error   | Output   | Possible cause  | Remedy  |
|---|--|---|---|
| <p>If the surface is not calm (e.g. filling, emptying, agitator running), the measured value jumps sporadically to a higher level</p> |  <p>L00-FMR2xxxx-19-00-00-en-015</p> <p>L00-FMR2xxxx-19-00-00-en-016</p> | <p>Signal is weakened by the rough surface – the interference echoes are sometimes stronger</p>   | <ol style="list-style-type: none"> <li>1. Carry out tank mapping → basic setup</li> <li>2. Set the process cond. (004) to "turb. surface" or "agitator"</li> <li>3. Increase the output damping (058)</li> <li>4. Optimise the orientation (see Page 68)</li> <li>5. If necessary, select a better mounting position and/or larger antenna (see Page 13)</li> </ol>               |
| <p>During filling/emptying the measured value jumps ownwards</p>  |  <p>L00-FMR2xxxx-19-00-00-en-017</p>                                    | <p>Multiple echoes</p>  | <p>yes →</p> <ol style="list-style-type: none"> <li>1. Check the tank shape (002), e.g. "dome ceiling" or "horizontal cyl"</li> <li>2. In the range of the blocking dist. (059) there is no echo evaluation → Adapt the value</li> <li>3. If possible, do not select central installation position (see Page 13)</li> <li>4. Perhaps use a stilling well (see Page 18)</li> </ol> |
| <p>E 641 (loss of echo)</p>   |  <p>L00-FMR2xxxx-19-00-00-en-018</p>                                    | <p>Level echo is too weak.</p> <p>Possible causes:</p> <ul style="list-style-type: none"> <li>• Rough surface due to filling/ emptying</li> <li>• Agitator running</li> <li>• Foam</li> </ul> | <p>yes →</p> <ol style="list-style-type: none"> <li>1. Check application parameters (002), (003) and (004)</li> <li>2. Optimise alignment (see Page 68)</li> <li>3. If necessary, select a better installation position and/or larger antenna (see Page 13)</li> </ol>  |
| <p>E 641 (loss of echo) after turn on the power supply</p>  | <p>If the instrument is configured to Hold by loss of echo the output is set to any value/</p>   | <p>noise level during the initialisation phase to high.</p>   | <p>Repeat once more empty calibr. (005).</p> <p>Caution!<br/>Before conformation change with <input type="checkbox"/> or <input type="checkbox"/> to the edit mode.</p>   |

## 9.4 Orientation of the Micropilot

For orientation a marker is found on the flange or threaded boss of the Micropilot. During installation this must be oriented as follows (see Page 9):

- In tanks: to the vessel wall
- In stilling wells: to the slots
- In bypass pipes: vertical to the tank connectors
- When using the Wave Guide antenna **no** orientation is required!

After commissioning the Micropilot, the echo quality indicates whether a sufficiently large measuring signal is obtained. If necessary, the quality can be optimised later. Vice versa, the presence of an interference echo can be used to minimise this by optimum orientation. The advantage of this is that the subsequent tank mapping uses a somewhat lower level that causes an increase in the strength of the measuring signal. Proceed as follows:



**Warning!**

Subsequent alignment can lead to personal injury. Before you unscrew or loosen the process connection, make sure that the vessel is not under pressure and does not contain any injurious substances.

1. It is best to empty the container so that the bottom is just covered. However, alignment can be carried out even if the vessel is empty.
2. Optimisation is best carried out with the aid of the envelope graph in the display or the ToF Tool.
3. Unscrew the flange or loosen the threaded boss by a half a turn.
4. Turn the flange by one hole or screw the threaded boss by one eighth of a turn. Note the echo quality.
5. Continue to turn until 360° is reached.
6. Optimum alignment:

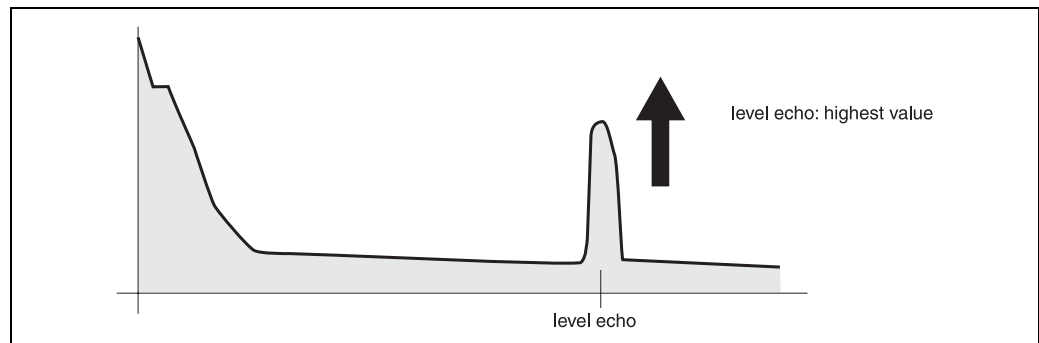

Fig. 5: Vessel partly full, no interference echo obtained

L00-FMRxxxx-19-00-00-en-002

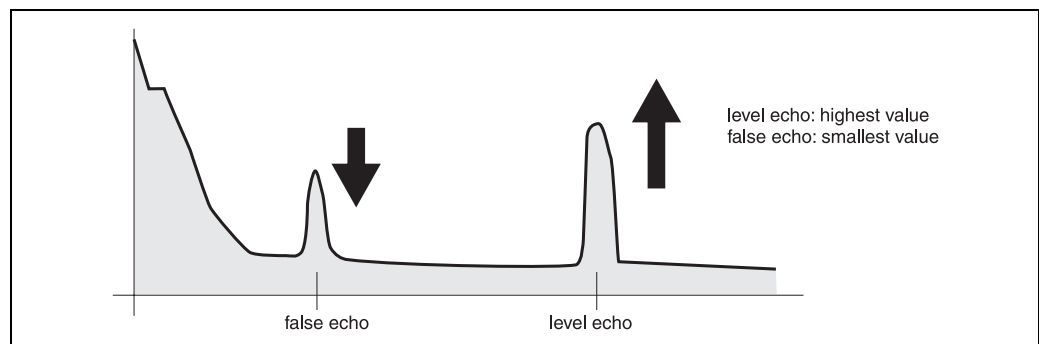

Fig. 6: Vessel partly full, interference echo obtained:

L00-FMRxxxx-19-00-00-en-003

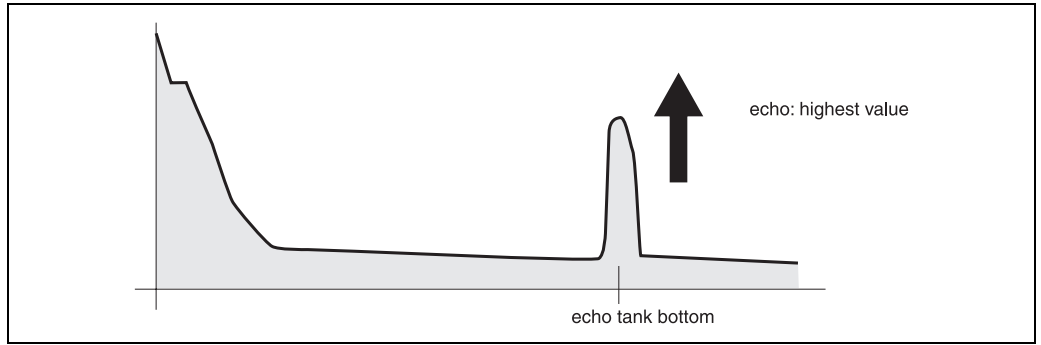

Fig. 7: Vessel empty, no interference echo

L00-FMRxxxxx-19-00-00-en-004

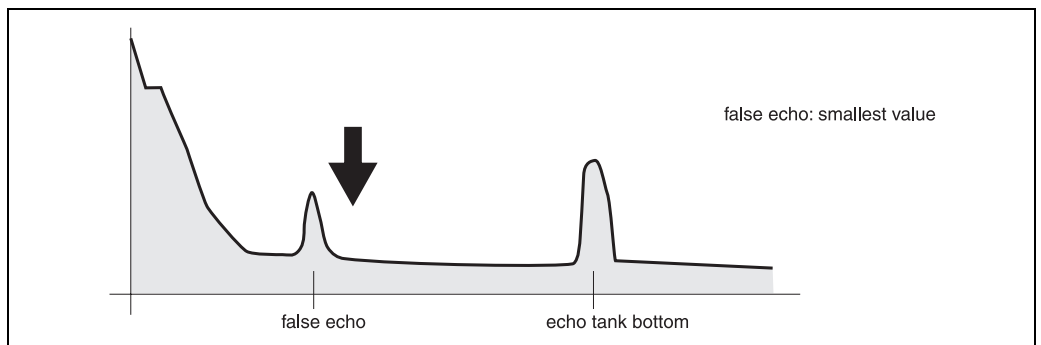

Fig. 8: Vessel empty, interference echo obtained

L00-FMRxxxxx-19-00-00-en-005

7. Fix the flange or threaded boss in this position.  
If necessary, replace the seal.
8. Carry out tank mapping, see Page 49.

## 9.5 Spare parts



Note!

You can order spare parts directly from your E+H service organization by giving the serial number which is printed on the measuring transducer nameplate (see Page 6s. Seite 6 ff.). The corresponding spare part number also appears on each spare part. Installation instructions are given on the instruction card that is also delivered.

### Spare parts Microplot M FMR 245, F12 housing with combined wiring and electronics compartment

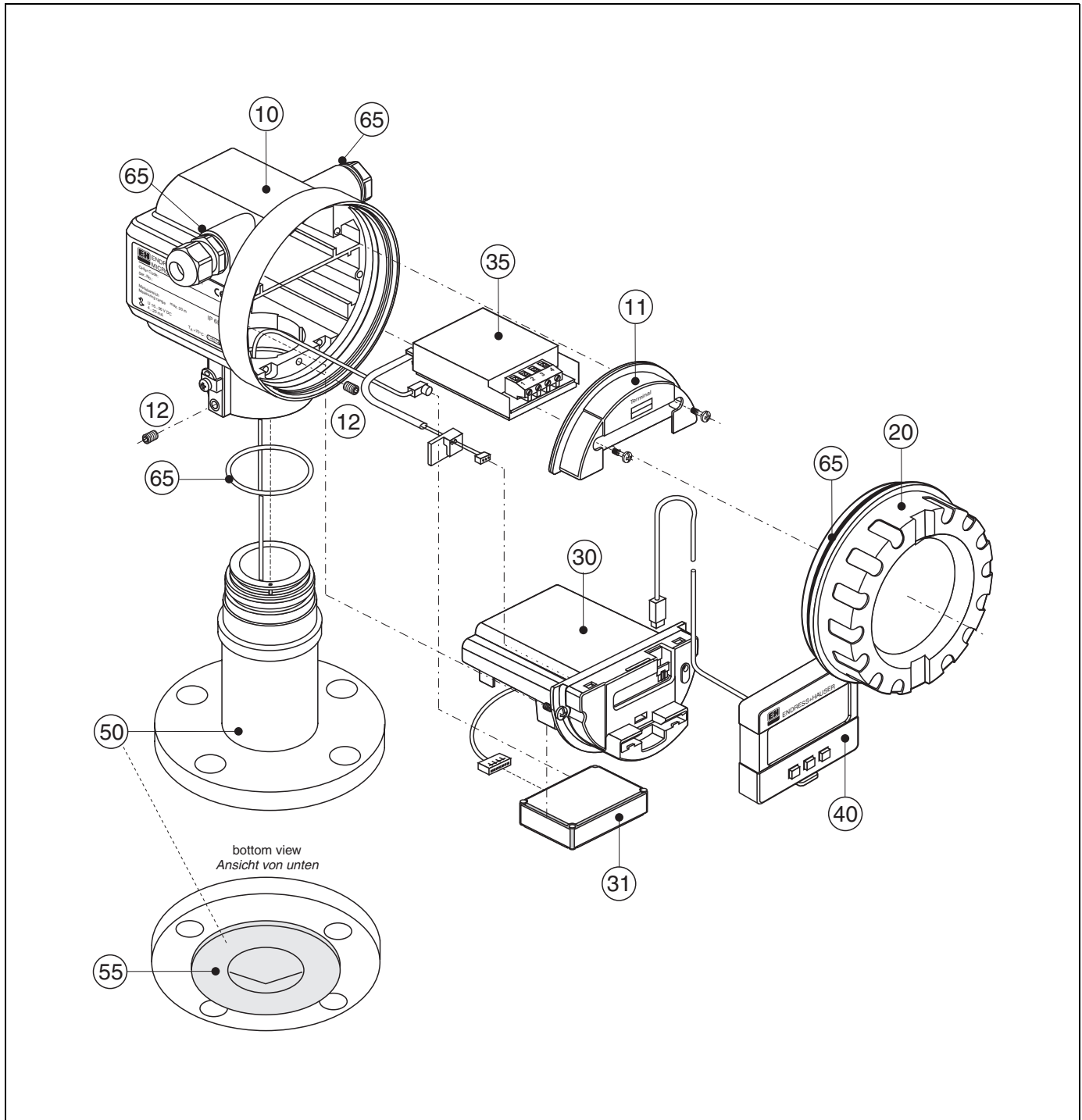

L00-FMR245xx-00-00-06-xx-001

**10 Housing**

|             |                                      |
|-------------|--------------------------------------|
| 543120-0022 | Housing F12, Aluminium, G1/2         |
| 543120-0023 | Housing F12, Aluminium, NPT1/2       |
| 543120-0024 | Housing F12, Aluminium, M20          |
| 52001992    | Housing F12, Aluminium, M20, PA-plug |
| 52008556    | Housing F12, Aluminium, M20, FF-plug |

**11 Hood for terminal compartment**

|          |                                      |
|----------|--------------------------------------|
| 52006026 | Cover terminal compartment F12       |
| 52019062 | Hood terminal compartment F12, FHX40 |

**12 Screw set**

|             |                               |
|-------------|-------------------------------|
| 535720-9020 | Set of screws housing F12/T12 |
|-------------|-------------------------------|

**20 Cover**

|             |   |
|-------------|---|
| 52005936    | Cover F12/T12 Aluminium, window, gasket |
| 517391-0011 | Cover F12/T12 Aluminium, coated, gasket |

**30 Electronics**

|          |  |
|----------|--|
| 52014976 | Electronics MICROPILOT-M, Ex, 2Dr, HART, 2.0           |
| 52014975 | Electronics MICROPILOT-M, Ex, PROFIBUS PA, 2.0         |
| 52014979 | Electronics MICROPILOT-M, Ex, Foundation Fieldbus, 2.0 |

**31 HF module**

|          |                                |
|----------|--------------------------------|
| 52006025 | HF module MICROPILOT-M, 26 GHz |
|----------|--------------------------------|

**35 Terminal module / power supply board**

|          |   |
|----------|---|
| 52006197 | Terminal module 4pole, HART, 2-wire with cable connection                                   |
| 52012156 | Terminal module 4pole, PROFIBUS PA, Foundation Fieldbus                                     |
| 52014817 | Terminal module 4pole, HART, ferrit (F12), GL marine certificate                            |
| 52014818 | Terminal module 4pole, PROFIBUS PA, Foundation Fieldbus ferrit (F12), GL marine certificate |

**40 Display**

|          |               |
|----------|---------------|
| 52005585 | Display VU331 |
|----------|---------------|

**50 Antenna assembly with process connection on request!**

**55 Cladding**

|          |   |
|----------|---|
| 52014436 | Cladding, flange DN50, PTFE disc                  |
| 52014435 | Cladding, flange DN80, PTFE disc                  |
| 52014431 | Cladding, flange DN100/ANSI 4", PTFE disc         |
| 52014429 | Cladding, flange DN150/JIS 150/ANSI 6", PTFE disc |
| 52014433 | Cladding, flange JIS 50A, PTFE disc               |
| 52014430 | Cladding, flange JIS 80/ANSI 3", PTFE disc        |
| 52014432 | Cladding, flange JIS 100A, PTFE disc              |
| 52014434 | Cladding, flange ANSI 2", PTFE disc               |

**65 Sealing kit**

|             |                            |
|-------------|----------------------------|
| 535720-9010 | consists of:               |
|             | 2 x gasket Pg13.5 FA       |
|             | 2 x O-ring 17.0x2.0 EPDM   |
|             | 1 x O-ring 49.21x3.53 EPDM |
|             | 2 x O-ring 17.12x2.62 FKM  |
|             | 1 x O-ring 113.9x3.63 EPDM |
|             | 1 x O-ring 72.0x3.0 EPDM   |



**Spare parts Micropilot M FMR 245, T12 housing with separate wiring and electronics compartment**

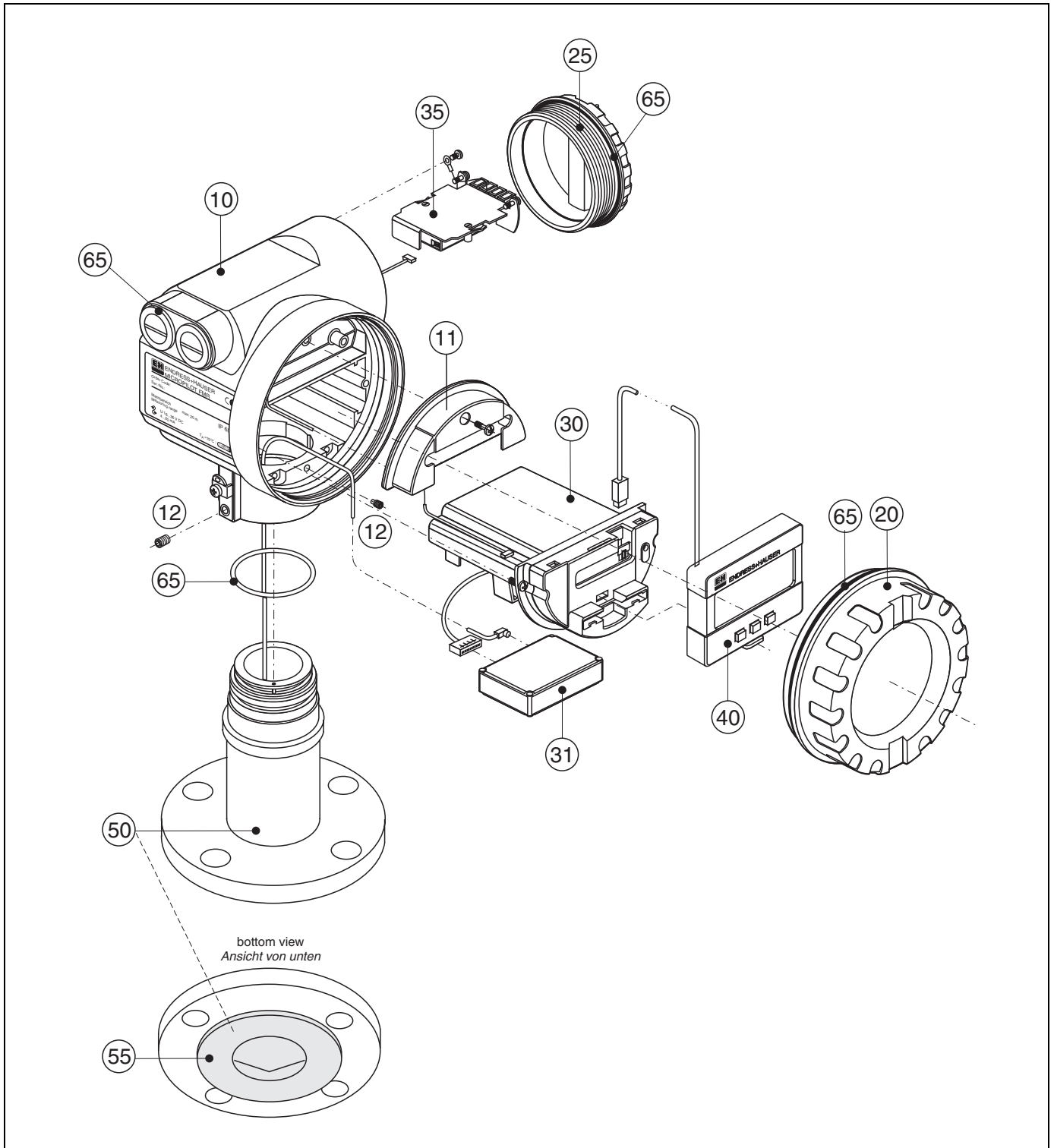

L00-FMR245xx-00-00-06-xx-002

**10 Housing**

|             |   |
|-------------|---|
| 543180-0022 | Housing T12, Aluminium, coated, G1/2, PAL         |
| 543180-0023 | Housing T12, Aluminium, coated, NPT1/2, PAL       |
| 543180-0024 | Housing T12, Aluminium, coated, M20, PAL          |
| 543180-1023 | Housing T12, Aluminium, NPT1/2, PAL, cover, EEx d |
| 52006204    | Housing T12, Aluminium, G1/2, PAL, cover, EEx d   |
| 52006205    | Housing T12, Aluminium, M20, PAL, cover, EEx d    |

**11 Hood for terminal compartment**

|          |          |
|----------|----------|
| 52005643 | Hood T12 |
|----------|----------|

**12 Screw set**

|             |                               |
|-------------|-------------------------------|
| 535720-9020 | Set of screws housing F12/T12 |
|-------------|-------------------------------|

**20 Cover**

|             |   |
|-------------|---|
| 52005936    | Cover F12/T12 Aluminium, window, gasket |
| 517391-0011 | Cover F12/T12 Aluminium, coated, gasket |

**25 Cover for terminal compartment**

|             |   |
|-------------|---|
| 518710-0020 | Cover T3/T12, Aluminium, coated, gasket |
|-------------|---|

**30 Electronics**

|          |  |
|----------|--|
| 52014976 | Electronics MICROPILOT-M, Ex, HART, 2.0                |
| 52014975 | Electronics MICROPILOT-M, Ex, PROFIBUS PA, 2.0         |
| 52014979 | Electronics MICROPILOT-M, Ex, Foundation Fieldbus, 2.0 |

**31 HF module**

|          |                                |
|----------|--------------------------------|
| 52006025 | HF module MICROPILOT-M, 26 GHz |
|----------|--------------------------------|

**35 Terminal module / power supply board**

|          |  |
|----------|--|
| 52013302 | Terminal module 4pole, 2-wire, HART, EEx d   |
| 52013303 | Terminal module 2pole, 2-wire, PROFIBUS PA / Foundation Fieldbus, EEx d                          |
| 52018949 | Terminal module 4pole, 2-wire, HART, EEx ia, overvoltage protection                              |
| 52018950 | Terminal module 4pole, 2-wire, PROFIBUS PA / Foundation Fieldbus, EEx ia, overvoltage protection |

**40 Display**

|          |               |
|----------|---------------|
| 52005585 | Display VU331 |
|----------|---------------|

**50 Antenna assembly with process connection on request!**

**55 Cladding**

|          |   |
|----------|---|
| 52014436 | Cladding, flange DN50, PTFE disc                  |
| 52014435 | Cladding, flange DN80, PTFE disc                  |
| 52014431 | Cladding, flange DN100/ANSI 4", PTFE disc         |
| 52014429 | Cladding, flange DN150/JIS 150/ANSI 6", PTFE disc |
| 52014433 | Cladding, flange JIS 50A, PTFE disc               |
| 52014430 | Cladding, flange JIS 80/ANSI 3", PTFE disc        |
| 52014432 | Cladding, flange JIS 100A, PTFE disc              |
| 52014434 | Cladding, flange ANSI 2", PTFE disc               |

**65 Sealing kit**

|             |                            |
|-------------|----------------------------|
| 535720-9010 | consists of:               |
|             | 2 x gasket Pg13.5 FA       |
|             | 2 x O-ring 17.0x2.0 EPDM   |
|             | 1 x O-ring 49.21x3.53 EPDM |
|             | 2 x O-ring 17.12x2.62 FKM  |
|             | 1 x O-ring 113.9x3.63 EPDM |
|             | 1 x O-ring 72.0x3.0 EPDM   |

**Spare parts Micropilot M FMR 245, F23 housing with combined wiring and electronics compartment****Stainless steel housing on request!****20 Cover**

|          |                                      |
|----------|--------------------------------------|
| 52018670 | Cover F23, 316L, sight glass, gasket |
| 52018671 | DeCoverckel F23, 316L, gasket        |

## 9.6 Return

The following procedures must be carried out before a transmitter is sent to Endress+Hauser e.g. for repair or calibration:

- Remove all residue which may be present. Pay special attention to the gasket grooves and crevices where fluid may be present. This is especially important if the fluid is dangerous to health, e.g. corrosive, poisonous, carcinogenic, radioactive, etc.
- Always enclose a duly completed "Declaration of contamination" form (a copy of the "Declaration of contamination" is included at the end of this operating manual). Only then can Endress +Hauser transport, examine and repair a returned device.
- Enclose special handling instructions if necessary, for example a safety data sheet as per EN 91/155/EEC.

Additionally specify:

- An exact description of the application.
- The chemical and physical characteristics of the product.
- A short description of the error that occurred (specify error code if possible)
- If necessary, give the error code.

## 9.7 Disposal

In case of disposal please separate the different components according to their material consistence.

## 9.8 Software history

| Software version / Date                      | Software changes  | Documentation changes         |
|--|---|-------------------------------|
| V 01.01.00 / 12.2000                         | Original software.<br>Operated via:<br>- ToF Tool from version 1.5<br>- Commuwin II (from version 2.07-3)<br>- HART communicator DXR 275 (from OS 4.6) with Rev. 1, DD 1.   |                               |
| V 01.02.00 / 05.2002<br>V 01.02.02 / 03.2003 | <ul style="list-style-type: none"> <li>• Function group: envelope curve display</li> <li>• Katakana (japanese)</li> <li>• current turn down (HART only)</li> <li>• the customer tank map can be edited</li> <li>• length of antenna extension FAR 10 can be entered directly</li> </ul> Operated via:<br>- ToF Tool from version 3.1<br>- Commuwin II (from version 2.08-1)<br>- HART communicator DXR 375 with Rev. 1, DD 1. | Description of new functions. |

## 9.9 Contact addresses of Endress+Hauser

The addresses of Endress+Hauser are given on the back cover of this operating manual. If you have any questions, please do not hesitate to contact your E+H representative.

## 10 Technical data

### 10.1 Additional technical data

#### 10.1.1 Input

---

|                   |   |
|-------------------|---|
| Measured variable | The measured variable is the distance between a reference point and a reflective surface (i.e. medium surface).<br>The level is calculated based on the tank height entered.<br>The level can be converted into other units (volume, mass) by means of a linearization. |
|-------------------|---|

#### 10.1.2 Output

---

|               |                              |
|---------------|------------------------------|
| Output signal | 4...20 mA with HART protocol |
|---------------|------------------------------|

---

|                 |   |
|-----------------|---|
| Signal on alarm | Error information can be accessed via the following interfaces: <ul style="list-style-type: none"> <li>• Local display:                     <ul style="list-style-type: none"> <li>– Error symbol (see Page 32)</li> <li>– Plain text display</li> </ul> </li> <li>• Current output</li> <li>• Digital interface</li> </ul> |
|-----------------|---|

---

|               |  |
|---------------|--|
| Linearization | The linearization function of the Micropilot M allows the conversion of the measured value into any unit of length or volume. Linearization tables for calculating the volume in cylindrical tanks are pre-programmed. Other tables of up to 32 value pairs can be entered manually or semi-automatically. |
|---------------|--|

#### 10.1.3 Auxiliary energy

---

|             |   |
|-------------|---|
| Ripple HART | 47...125 Hz: $U_{ss} = 200 \text{ mV}$ (at $500 \Omega$ ) |
|-------------|---|

---

|                 |  |
|-----------------|--|
| Max. noise HART | 500 Hz...10 kHz: $U_{eff} = 2.2 \text{ mV}$ (at $500 \Omega$ ) |
|-----------------|--|

#### 10.1.4 Performance characteristics

---

|                                |  |
|--------------------------------|--|
| Reference operating conditions | <ul style="list-style-type: none"> <li>• temperature = <math>+20 \text{ °C}</math> (<math>68 \text{ °F}</math>) <math>\pm 5 \text{ °C}</math> (<math>9 \text{ °F}</math>)</li> <li>• pressure = <math>1013 \text{ mbar abs.}</math> (<math>14.7 \text{ psia}</math>) <math>\pm 20 \text{ mbar}</math> (<math>0.3 \text{ psi}</math>)</li> <li>• relative humidity (air) = <math>65 \%</math> <math>\pm 20\%</math></li> <li>• ideal reflector</li> <li>• no major interference reflections inside the signal beam</li> </ul> |
|--------------------------------|--|

---

|                        |   |
|------------------------|---|
| Maximum measured error | Typical statements for reference conditions, include linearity, repeatability, and hysteresis: <ul style="list-style-type: none"> <li>• FMR 245: up to <math>10 \text{ m} \pm 3 \text{ mm}</math>, off <math>10 \text{ m} \pm 0,03\%</math> of measuring range</li> </ul> |
|------------------------|---|

|                                   |   |
|-----------------------------------|---|
| Resolution                        | Digital / analog in % 4...20 mA<br><ul style="list-style-type: none"> <li>• FMR 245: 1mm / 0.03 % of measuring range</li> </ul>   |
| Reaction time                     | The reaction time depends on the parameter settings (min. 1 s). In case of fast level changes, the instrument needs the reaction time to indicate the new value.  |
| Influence of ambiente temperature | The measurements are carried out in accordance with EN 61298-3:<br><ul style="list-style-type: none"> <li>• Current output (additional error, in reference to the span of 16 mA): <ul style="list-style-type: none"> <li>– <b>Zero point (4 mA)</b><br/> average <math>T_K</math>: 0,03 %/10 K, max. 0,45 % over the entire temperature range -40 °C...+80 °C</li> <li>– <b>Span (20 mA)</b><br/> average <math>T_K</math>: 0,09 %/10 K, max. 0,95 % over the entire temperature range -40 °C...+80 °C</li> </ul> </li> </ul> |

### 10.1.5 Operating conditions: Environment

|                           |   |
|---------------------------|---|
| Ambient temperature range | Ambient temperature for the transmitter: -40 °C ... +80 °C (-40 °F ... +176 °F), -50 °C (-58 °F) on request.<br>The functionality of the LCD display may be limited for temperatures $T_a < -20$ °C and $T_a > +60$ °C.<br>A weather protection cover should be used for outdoor operation if the instrument is exposed to direct sunlight.   |
| Storage temperature       | -40 °C ... +80 °C (-40 °F ... +176 °F), -50 °C (-58 °F) on request.   |
| Climate class             | DIN EN 60068-2-38 (test Z/AD)   |
| Vibration resistance      | DIN EN 60068-2-64 / IEC 68-2-64: 20...2000 Hz, 1 (m/s <sup>2</sup> ) <sup>2</sup> /Hz<br>This value can be reduced for Wave Guide antennas, depending on the length. In the event of horizontal stress, mechanical support is required or provide the Wave Guide antenna with a protective pipe.  |
| Cleaning of the antenna   | The antenna can get contaminated, depending on the application. The emission and reception of microwaves can thus eventually be hindered. The degree of contamination leading to an error depends on the medium and the reflectivity, mainly determined by the dielectric constant $\epsilon_r$ . If the medium tends to cause contamination and deposits, cleaning on a regular basis is recommended. Care has to be taken not to damage the antenna in the process of a mechanical or hose-down cleaning (eventually connection for cleaning liquid). The material compatibility has to be considered if cleaning agents are used!<br>The maximum permitted temperature at the flange should not be exceeded. |

Electromagnetic compatibility

- Interference Emission to EN 61326, Electrical Equipment Class B
- Interference Immunity to EN 61326, Annex A (Industrial) and NAMUR Recommendation NE 21 (EMC)
- A standard installation cable is sufficient if only the analogue signal is used. Use a screened cable when working with a superimposed communications signal (HART).

### 10.1.6 Operating conditions: Process

|                               |  |
|-------------------------------|--|
| Type of antenna / Temperature | -40 °C...+150 °C (-40 °F...+302 °F)      |
| Pressure                      | vacuum...16 bar (...232 psi)             |
| Antenna                       | PTFE-clad                                |
| Wetted parts                  | PTFE (TFM 1600, FDA-listed) <sup>1</sup> |

1) 3A/EHEDG approval for Tri-clamp process connection.

Dielectric constant

- in a stilling well/Wave Guide antenna:  $\epsilon_r \geq 1,4$
- in free space:  $\epsilon_r \geq 1,9$

### 10.1.7 Mechanical construction

Weight

- F12/T12 housing: approx 4 kg + weight of flange
- F23 housing: approx 7.4 kg + weight of flange

### 10.1.8 Certificates and approvals

CE approval

The measuring system meets the legal requirements of the EC-guidelines. Endress+Hauser confirms the instrument passing the required tests by attaching the CE-mark.

RF approvals

R&TTE, FCC

Overspill protection

german WHG, see ZE 244F/00/de.  
SIL 2, see SD 150F/00/en "Functional Safety Manual".

External standards and guidelines

**EN 60529**  
Protection class of housing (IP-code)

**EN 61010**  
Safety regulations for electrical devices for measurement, control, regulation and laboratory use.

**EN 61326**  
Emissions (equipment class B), compatibility (appendix A - industrial area)

**NAMUR**  
Standards committee for measurement and control in the chemical industry



|             |  |
|-------------|--|
| Ex approval | <b>XA 103F-D</b><br>Installation Micropilot M FMR 2xx<br>(F12 / PTFE antenna, non-conductive / EEx ia IIC T6)<br>PTB 00 ATEX 2117 X, Equipment marking: (II 1/2 G)                             |
|             | <b>XA 105F-D</b><br>Installation Micropilot M FMR 2xx<br>(T12 / PTFE antenna, non-conductive / EExd [ia] IIC T6)<br>PTB 00 ATEX 2117 X, Equipment marking: (II 1/2 G)                          |
|             | <b>XA 205F-B</b><br>Installation Micropilot M FMR 2xx<br>(F23 / PTFE antenna, non-conductive / EEx ia IIC T6)<br>PTB 00 ATEX 2117 X, Equipment marking: (II 1/2 G)                             |
|             | <b>XA 209F-B</b><br>Installation Micropilot M FMR 2xx<br>(T12 with overvoltage protection / PTFE antenna, non-conductive / EEx ia IIC T6)<br>PTB 00 ATEX 2117 X, Equipment marking: (II 1/2 G) |
|             | <b>XA 233F-A</b><br>Installation Micropilot M FMR 2xx<br>(ATEX II 3 G EEx nA IIC T6, in preparation)   |

|                    |   |
|--------------------|---|
| Marine certificate | GL (German Lloyd)<br>– HART, PROFIBUS PA<br>– not Wave Guided antenna, not HT antenna |
|--------------------|---|

### 10.1.9 Supplementary Documentation

|                             |   |
|-----------------------------|---|
| Supplementary Documentation | <ul style="list-style-type: none"> <li>• System Information Micropilot (SI 019F/00/en)</li> <li>• Technical Information (TI 345F/00/en)</li> <li>• Operating Instructions "Description of instrument functions" (BA 221F/00/en)</li> <li>• Safety Manual "Functional Safety Manual" (SD 150F/00/en).</li> </ul> |
|-----------------------------|---|

# 11 Appendix

## 11.1 Operating menu HART (display modul), ToF Tool

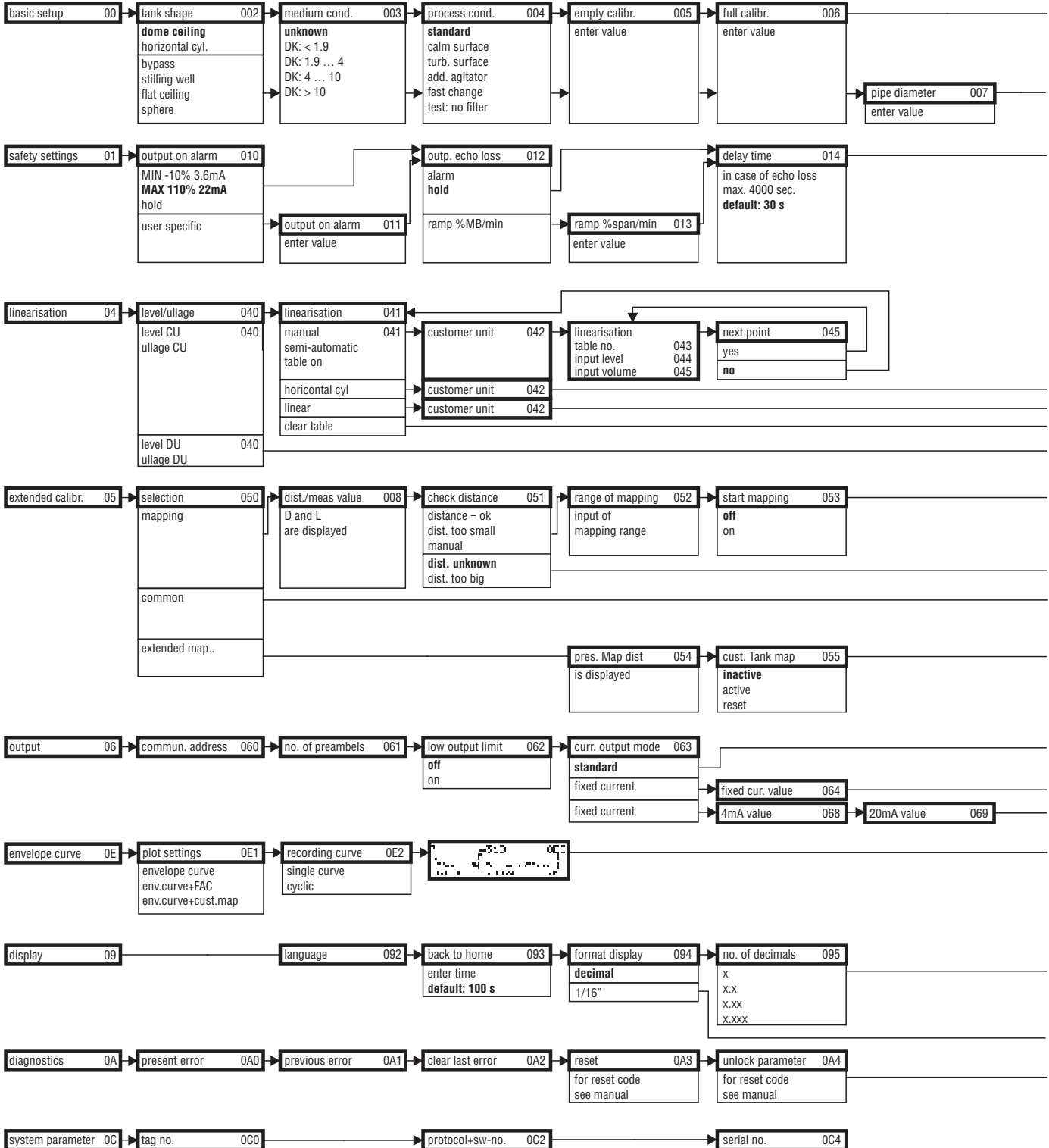

**Note!** The default values of the parameters are typed in boldface.

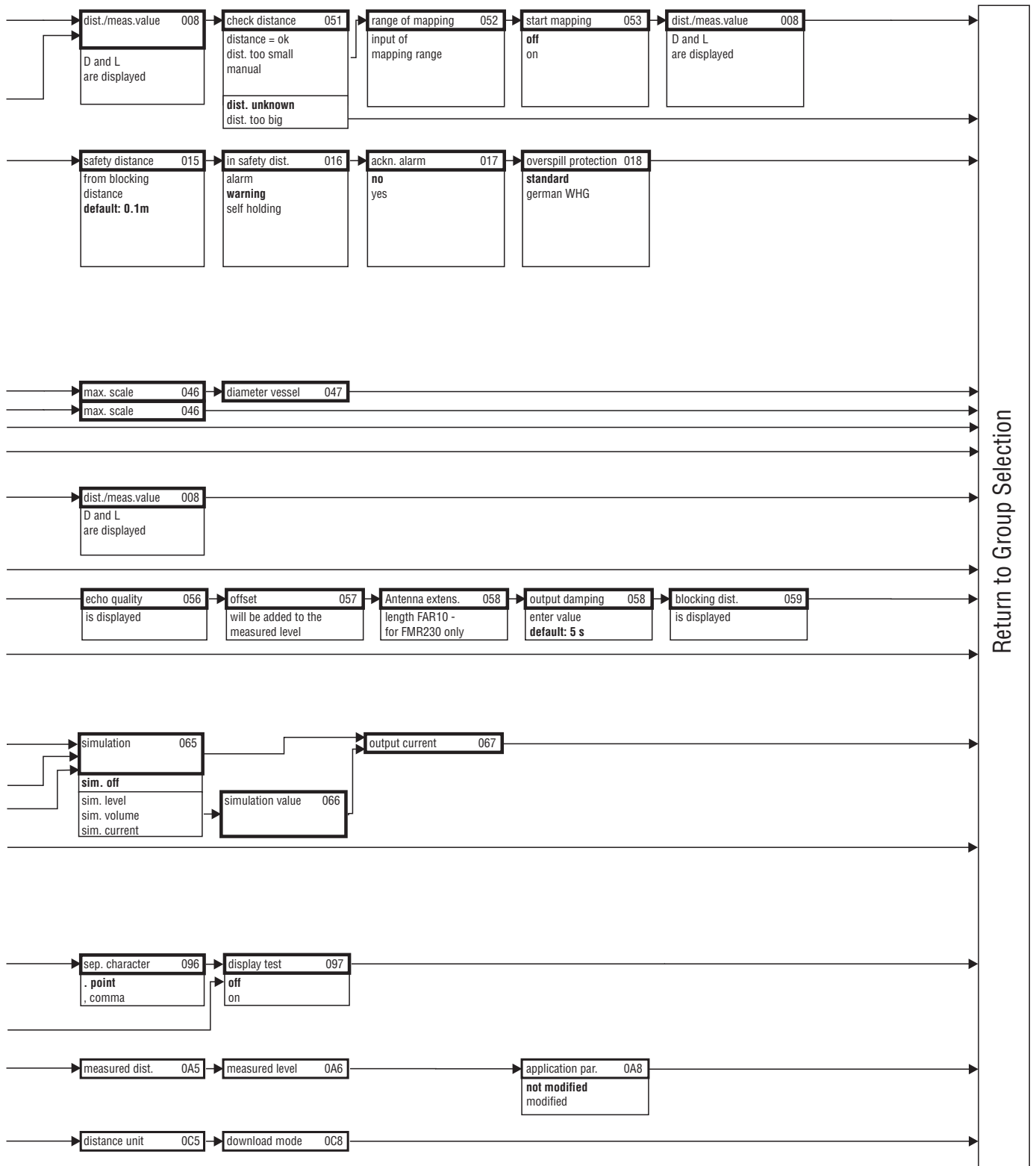

## 11.2 Operating matrix HART / Commuwin II

### Operating Matrix HART / COMMUWIN II

| Function group      | V-CWII | H0              | H1               | H2               | H3               | H4               | H5              | H6               | H7              | H8                   | H9             |
|---------------------|--------|-----------------|------------------|------------------|------------------|------------------|-----------------|------------------|-----------------|----------------------|----------------|
| 00 basic setup      | V0     | measured value  |                  | tank shape       | medium property  | process cond.    | empty calibr.   | full calibr.     | pipe diameter   |                      |                |
| 01 safety settings  | V1     | output on alarm | output on alarm  | oup. echo loss   | ramp %span/min   | delay time       | safety distance | in safety dist.  | ackn. alarm     | overspill protection |                |
| 04 linearisation    | V3     | level/ullage    | linearisation    | customer unit    | table no.        | input level      | input volume    | max. scale       | diameter vessel |                      |                |
| 05 extended calibr. | V4     |                 | check distance   | range of mapping | start mapping    | pres. Map dist   | cust. Tank map  | echo quality     | offset          | output damping       | blocking dist. |
| 06 output           | V5     | commun. address | no. of preambels | low output limit | curr.output mode | fixed cur. value | simulation      | simulation value | output current  | 4mA value            | 20mA value     |
| 09 display          | V6     |                 |                  | language         | back to home     | format display   | no.of decimals  | sep. character   |                 |                      |                |
| 0D service          | V7     |                 |                  |                  |                  |                  |                 |                  |                 |                      |                |
| 0A diagnostics      | V9     | present error   | previous error   | clear last error | reset            | unlock parameter | measured dist.  | measured level   |                 | application par.     |                |
| 0C system parameter | VA     | tag no.         |                  | protocol-hsw-no. |                  | serial no.       | distance unit   |                  |                 | download mode        | antenna ext.   |

L00-FMR2xxxx-19-00-00-de-000

### 11.3 Description of functions



Note!

A detailed description of the function groups, functions and parameters is given in the documentation BA 221F/00/en "Description of the instrument functions of the Micropilot M" on the enclosed CD-ROM.

## 11.4 Function and system design

### 11.4.1 Function (Measuring principle)

The Micropilot is a "downward-looking" measuring system, operating based on the time-of-flight method. It measures the distance from the reference point (process connection) to the product surface. Radar impulses are emitted by an antenna, reflected off the product surface and received again by the radar system.

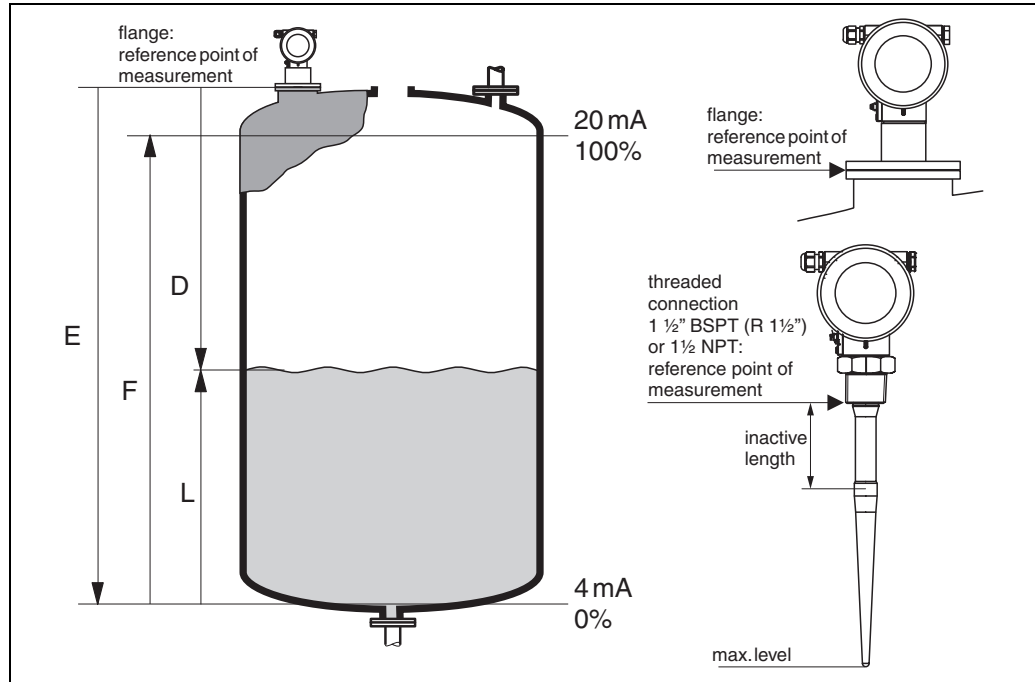

L00-FMR2xxxx-15-00-00-en-001

### Input

The reflected radar impulses are received by the antenna and transmitted into the electronics. A microprocessor evaluates the signal and identifies the level echo caused by the reflection of the radar impulse at the product surface. The unambiguous signal identification is accomplished by the PulseMaster® software, based on many years of experience with time-of-flight technology.

The mm-accuracy of the Micropilot S could be achieved with the patented algorithms of the PhaseMaster® software.

The distance  $D$  to the product surface is proportional to the time of flight  $t$  of the impulse:

$$D = c \cdot t/2,$$

with  $c$  being the speed of light.

Based on the known empty distance  $E$ , the level  $L$  is calculated:

$$L = E - D$$

Refer to the above figure for the reference point for "E".

The Micropilot is equipped with functions to suppress interference echoes. The user can activate these functions. They ensure that interference echoes (i.e. from edges and weld seams) are not interpreted as level echo.

**Output**

The Micropilot is commissioned by entering an empty distance E (=zero), a full distance F (=span) and an application parameter. The application parameter automatically adapts the instrument to the process cond.. The data points “E” and “F” correspond with 4mA and 20mA for instruments with current output. They correspond with 0 % and 100 % for digital outputs and the display module.

A linearization with max. 32 points, based on a table entered either manually or semi-automatically, can be activated locally or remotely. This function provides a measurement in engineering units and a linear output signal for spheres, horizontal cylindrical tanks and vessels with conical outlet.

**11.4.2 Equipment architecture**

**Stand-alone**

The Micropilot M can be used for measurement in a stilling well / bypass as well as in free space.

The instrument provides a 4...20 mA output with HART protocol, or PROFIBUS PA respectively Foundation Fieldbus communication.

**4...20 mA output with HART protocol**

The complete measuring system consists of:

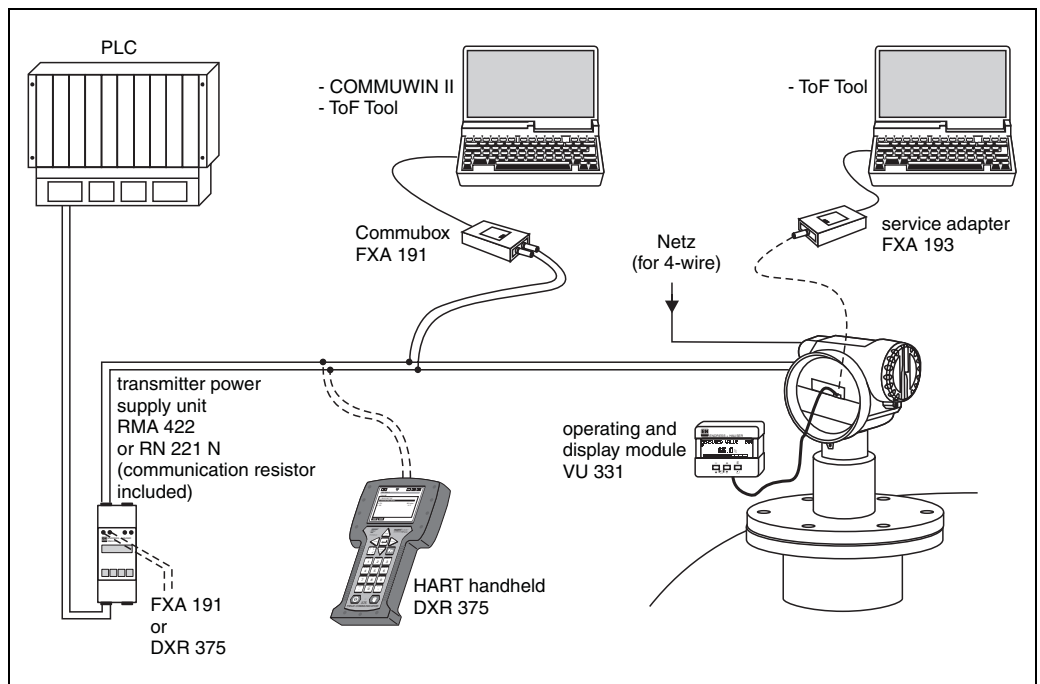

If the HART communication resistor is not built into the supply unit, it is necessary to insert a communication resistor of 250 Ω into the 2-wire line.

**On-site operation**

- with display and operating module VU 331,
- with a Personal Computer, FXA 193 and the operating software ToF Tool.  
The ToF Tool is a graphical operating software for instruments from Endress+Hauser that operate based on the time-of-flight principle (radar, ultrasonic, guided micro-impulse). It assists with commissioning, securing data, signal analysis and documentation of the measuring point.

**Remote operation**

- with HART handheld DXR 275,
- with a Personal Computer, Commubox FXA 191 and the operating software COMMUWIN II respectively ToF Tool.

**11.4.3 Patents**

This product may be protected by at least one of the following patents.  
Further patents are pending.

- US 5,387,918  $\cong$  EP 0 535 196
- US 5,689,265  $\cong$  EP 0 626 063
- US 5,659,321
- US 5,614,911  $\cong$  EP 0 670 048
- US 5,594,449  $\cong$  EP 0 676 037
- US 6,047,598
- US 5,880,698
- US 5,926,152
- US 5,969,666
- US 5,948,979
- US 6,054,946
- US 6,087,978
- US 6,014,100



## Index

### A

accessories . . . . . 61  
 alarm . . . . . 36  
 antenna size . . . . . 11  
 application errors . . . . . 66

### B

basic setup . . . . . 41, 43, 55  
 beam angle . . . . . 14  
 bypass . . . . . 20, 48

### C

CE mark . . . . . 8  
 commissioning . . . . . 40  
 Commubox . . . . . 27, 61  
 Commuwin II . . . . . 27, 39, 61  
 connecting . . . . . 25  
 connection . . . . . 27–28

### D

declaration of conformity . . . . . 8  
 declaration of contamination . . . . . 77  
 degree of protection . . . . . 28  
 designated use . . . . . 4  
 dielectric constant . . . . . 16, 44  
 dimensions . . . . . 11  
 display . . . . . 31  
 disposal . . . . . 77  
 distance . . . . . 41, 49  
 DXR 375 . . . . . 27

### E

echo mapping . . . . . 50  
 echo quality . . . . . 68–69  
 empty calibration . . . . . 41, 46, 56–58  
 engineering hints . . . . . 13  
 envelope curve . . . . . 52, 59  
 equipotential bonding . . . . . 28  
 error messages . . . . . 36  
 Ex approval . . . . . 80  
 exterior cleaning . . . . . 60

### F

F12 housing . . . . . 23, 25  
 foam . . . . . 15  
 full calibration . . . . . 41, 47, 56–58  
 function . . . . . 86  
 function groups . . . . . 30  
 functions . . . . . 30  
 FXA 191 . . . . . 27  
 FXA 193 . . . . . 27

### H

handheld unit DXR 375 . . . . . 37  
 HART . . . . . 25, 27, 37

### I

installation in bypass . . . . . 20  
 installation in stilling well . . . . . 9, 18  
 installation in tank . . . . . 9, 17  
 interference echo . . . . . 68  
 interference echoes . . . . . 49

### K

key assignment . . . . . 32

### L

level . . . . . 41  
 lock . . . . . 33–34

### M

maintenance . . . . . 60  
 mapping . . . . . 49–50, 58–59  
 maximum measured error . . . . . 78  
 measuring conditions . . . . . 15  
 measuring principle . . . . . 86  
 medium property . . . . . 44, 56  
 mounting . . . . . 9

### N

nameplate . . . . . 6  
 notes on safety conventions and symbols . . . . . 5

### O

operatin menu . . . . . 82  
 operating menu . . . . . 30  
 operation . . . . . 29, 33  
 operation menu . . . . . 29  
 operational safety . . . . . 4  
 optimisation . . . . . 68  
 ordering structure . . . . . 6  
 orientation . . . . . 9, 68

### P

pipe diameter . . . . . 48  
 process conditions . . . . . 45  
 product class . . . . . 16

### R

repairs . . . . . 60  
 repairs to Ex-approved devices . . . . . 60  
 replacement . . . . . 60  
 replacing seals . . . . . 60  
 Reset . . . . . 35  
 return . . . . . 77  
 RF approvals . . . . . 80  
 RMA 422 . . . . . 27  
 RN 221 N . . . . . 27

### S

safety distance . . . . . 41  
 safety instructions . . . . . 4  
 service adapter FXA 193 . . . . . 61

|                             |        |
|-----------------------------|--------|
| software history .....      | 77     |
| spare parts .....           | 70     |
| stilling well .....         | 18, 48 |
| stilling wells .....        | 19     |
| system error messages ..... | 64     |

**T**

|                                     |                    |
|-------------------------------------|--------------------|
| T12 housing .....                   | 24–25              |
| tank installations .....            | 13                 |
| tank shape .....                    | 43, 56             |
| technical data .....                | 78                 |
| terminal compartment .....          | 25                 |
| ToF Tool .....                      | 27, 37, 55, 59, 82 |
| trouble-shooting .....              | 63                 |
| trouble-shooting instructions ..... | 63                 |
| turn housing .....                  | 9, 22              |

**U**

|                        |       |
|------------------------|-------|
| unlock parameter ..... | 33–34 |
|------------------------|-------|

**V**

|              |        |
|--------------|--------|
| VU 331 ..... | 43, 52 |
|--------------|--------|

**W**

|                                |    |
|--------------------------------|----|
| warning .....                  | 36 |
| weather protection cover ..... | 61 |
| wiring .....                   | 23 |

## Declaration of contamination

Dear customer,  
Because of legal determinations and for the safety of our employees and operating equipment we need this "Declaration of contamination" with your signature before your order can be handled. Please put the completely filled in declaration to the instrument and to the shipping documents in any case. Add also safety sheets and/or specific handling instructions if necessary.

type of instrument / sensor: \_\_\_\_\_ serial number: \_\_\_\_\_  
medium / concentration: \_\_\_\_\_ temperature: \_\_\_\_\_ pressure: \_\_\_\_\_  
cleaned with: \_\_\_\_\_ conductivity: \_\_\_\_\_ viscosity: \_\_\_\_\_

### Warning hints for medium used:



radioactive



explosive



caustic



poisonous



harmful of  
health



biological  
hazardous



inflammable



safe

Please mark the appropriate warning hints.

### Reason for return:

\_\_\_\_\_  
\_\_\_\_\_

### Company data:

|                |                       |
|----------------|-----------------------|
| company: _____ | contact person: _____ |
| _____          | _____                 |
| _____          | department: _____     |
| address: _____ | phone number: _____   |
| _____          | Fax/E-Mail: _____     |
| _____          | your order no.: _____ |

I hereby certify that the returned equipment has been cleaned and decontaminated acc. to good industrial practices and is in compliance with all regulations. This equipment poses no health or safety risks due to contamination.

\_\_\_\_\_  
(Date)

\_\_\_\_\_  
(company stamp and legally binding signature)

More information about services and repairs:  
[www.services.endress.com](http://www.services.endress.com)

# Endress+Hauser

The Power of Know How



## Europe

### Austria – Wien

□ Endress+Hauser Ges.m.b.H.  
Tel. (01) 88 05 60, Fax (01) 88 05 63 35

### Belarus – Minsk

Belorgsintez  
Tel. (017) 2 50 84 73, Fax (017) 2 50 85 83

### Belgium / Luxembourg – Bruxelles

□ Endress+Hauser S.A. / N.V.  
Tel. (02) 2 48 06 00, Fax (02) 2 48 05 53

### Bulgaria – Sofia

Intertech-Automation Ltd.  
Tel. (02) 9 62 71 52, Fax (02) 9 62 14 71

### Croatia – Zagreb

□ Endress+Hauser GmbH+Co.  
Tel. (01) 6 63 77 85, Fax (01) 6 63 78 23

### Cyprus – Nicosia

I+G Electrical Services Co. Ltd.  
Tel. (02) 48 47 88, Fax (02) 48 46 90

### Czech Republic – Praha

□ Endress+Hauser Czech s.r.o.  
Tel. (02) 66 78 42 00, Fax (026) 66 78 41 79

### Denmark – Søborg

□ Endress+Hauser A/S  
Tel. (70) 13 11 32, Fax (70) 13 21 33

### Estonia – Tartu

Elvi-Aqua OU  
Tel. (7) 30 27 32, Fax (7) 30 27 31

### Finland – Helsinki

□ Metso Endress+Hauser Oy  
Tel. (204) 8 31 60, Fax (204) 8 31 61

### France – Huingue

□ Endress+Hauser S.A.  
Tel. (389) 69 67 68, Fax (389) 69 48 02

### Germany – Weil am Rhein

□ Endress+Hauser Messtechnik GmbH+Co. KG  
Tel. (07621) 9 75 01, Fax (07621) 97 55 55

### Great Britain – Manchester

□ Endress+Hauser Ltd.  
Tel. (0161) 2 86 50 00, Fax (0161) 9 98 18 41

### Greece – Athens

I & G Building Services Automation S.A.  
Tel. (01) 9 24 15 00, Fax (01) 9 22 17 14

### Hungary – Budapest

□ Endress+Hauser Magyarország  
Tel. (01) 4 12 04 21, Fax (01) 4 12 04 24

### Iceland – Reykjavik

Sindra-Stál hf  
Tel. 5 75 00 00, Fax 5 75 00 10

### Ireland – Clane / County Kildare

□ Flomeaco Endress+Hauser Ltd.  
Tel. (045) 86 86 15, Fax (045) 86 81 82

### Italy – Cernusco s/N, Milano

□ Endress+Hauser S.p.A.  
Tel. (02) 92 19 21, Fax (02) 92 19 23 62

### Latvia – Riga

Elekoms Ltd.  
Tel. (07) 33 64 44, Fax (07) 33 64 48

### Lithuania – Kaunas

UAB Agava Ltd.  
Tel. (03) 7 20 24 10, Fax (03) 7 20 74 14

### Macedonia – Beograd

Meris d.o.o.  
Tel. (11) 44 42 96 6, Fax (11) 30 85 77 8

### Moldavia – Chisinau

S.C. Techno Test SRL  
Tel. (02) 22 61 60, Fax (02) 22 83 13

### Netherlands – Naarden

□ Endress+Hauser B.V.  
Tel. (035) 6 95 86 11, Fax (035) 6 95 88 25

### Norway – Lierskogen

□ Endress+Hauser A/S  
Tel. 32 85 98 50, Fax 32 85 98 51

### Poland – Wroclaw

□ Endress+Hauser Polska Sp. z o.o.  
Tel. (071) 7 80 37 00, Fax (071) 7 80 37 60

### Portugal – Cacem

□ Endress+Hauser Lda.  
Tel. (21) 4 26 72 90, Fax (21) 4 26 72 99

### Romania – Bucharest

Romconseng S.R.L.  
Tel. (021) 41 12 50 1, Fax (021) 41 01 63 4

### Russia – Moscow

□ Endress+Hauser GmbH+Co  
Tel. (095) 78 32 85 0, Fax (095) 78 32 85 5

### Slovak Republic – Bratislava

Transcom Technik s.r.o.  
Tel. (2) 44 88 86 90, Fax (2) 44 88 71 12

### Slovenia – Ljubljana

□ Endress+Hauser (Slovenija) D.O.O.  
Tel. (01) 5 19 22 17, Fax (01) 5 19 22 98

### Spain – Sant Just Desvern

□ Endress+Hauser S.A.  
Tel. (93) 4 80 33 66, Fax (93) 4 73 38 39

### Sweden – Sollentuna

□ Endress+Hauser AB  
Tel. (08) 55 51 16 00, Fax (08) 55 51 16 55

### Switzerland – Reinach/BL 1

□ Endress+Hauser Metso AG  
Tel. (061) 7 15 75 75, Fax (061) 7 11 16 50

### Turkey – Levent/Istanbul

Intek Endüstriyel Ölçü ve Kontrol Sistemleri  
Tel. (0212) 2 75 13 55, Fax (0212) 2 66 27 75

### Ukraine – Kiev

Photonika GmbH  
Tel. (44) 2 68 81 02, Fax (44) 2 69 07 05

### Yugoslavia Republic – Beograd

Meris d.o.o.  
Tel. (11) 4 44 29 66, Fax (11) 3 08 57 78

## Africa

### Algeria – Annaba

Symes Systemes et Mesures  
Tel. (38) 88 30 03, Fax (38) 88 30 02

### Egypt – Heliopolis/Cairo

Anasia Egypt For Trading (S.A.E.)  
Tel. (02) 2 68 41 59, Fax (02) 2 68 41 69

### Morocco – Casablanca

Oussama S.A.  
Tel. (02) 22 24 13 38, Fax (02) 2 40 26 57

### Rep. South Africa – Sandton

□ Endress+Hauser (Pty.) Ltd.  
Tel. (011) 2 62 80 00, Fax (011) 2 62 80 62

### Tunisia – Tunis

CMR Controle, Maintenance et Regulation  
Tel. (07) 17 93 07 7, Fax (07) 17 88 59 5

## America

### Argentina – Buenos Aires

□ Endress+Hauser Argentina S.A.  
Tel. (11) 45 22 79 70, Fax (11) 45 22 79 09

### Brazil – Sao Paulo

□ Samson Endress+Hauser Ltda.  
Tel. (011) 50 33 43 33, Fax (011) 50 31 30 67

### Canada – Burlington, Ontario

□ Endress+Hauser Canada Ltd.  
Tel. (905) 68 19 29 2, Fax (905) 68 19 44 4

### Chile – Santiago de Chile

□ Endress+Hauser (Chile) Ltd.  
Tel. (02) 3 21 30 09, Fax (02) 3 21 30 25

### Colombia – Bogota D.C.

Colsein Ltda.  
Tel. (01) 2 36 76 59, Fax (01) 6 10 78 68

### Costa Rica – San Jose

Euro-Tec S.A.  
Tel. 2 20 28 08, Fax 2 96 15 42

### Ecuador – Quito

Insetec Cia. Ltda.  
Tel. (02) 2 26 91 48, Fax (02) 2 46 18 33

### El Salvador – San Salvador

Automatizacion y Control Industrial de El Salvador, S.A. de C.V.  
Tel. 2 60 24 24, Fax 2 60 56 77

### Guatemala – Ciudad de Guatemala

Automatizacion y Control Industrial, S.A.  
Tel. (03) 34 59 85, Fax (03) 32 74 31

### Honduras – San Pedro Sula, Cortes

Automatizacion y Control Industrial de Honduras, S.A. de C.V.  
Tel. 5 57 91 36, Fax 5 57 91 39

### Mexico – México, D.F

□ Endress+Hauser (México), S.A. de C.V.  
Tel. (5) 5 55 68 24 07, Fax (5) 5 55 68 74 59

### Nicaragua – Managua

Automatización y Control Industrial de Nicaragua, S.A.  
Tel. 2 22 61 90, Fax 2 28 70 24

### Peru – Miraflores

Corsua International  
Tel. (1) 44 41 20 0, Fax (1) 44 43 66 4

### USA – Greenwood, Indiana

□ Endress+Hauser Inc.  
Tel. (317) 5 35 71 38, Fax (317) 5 35 84 98

### USA – Norcross, Atlanta

□ Endress+Hauser Systems & Gauging Inc.  
Tel. (770) 4 47 92 02, Fax (770) 4 47 57 67

### Venezuela – Caracas

Controlval C.A.  
Tel. (212) 9 44 09 66, Fax (212) 9 44 45 54

## Asia

### Azerbaijan – Baku

Modcon Systems - Baku  
Tel. (12) 92 98 59, Fax (12) 99 13 72

### Brunei – Negara Brunei Darussalam

American International Industries (B) Sdn. Bhd.  
Tel. (3) 22 37 37, Fax (3) 22 54 58

### Cambodia – Khan Daun Penh, Phom Penh

Comin Khmere Co. Ltd.  
Tel. (23) 42 60 56, Fax (23) 42 66 22

### China – Shanghai

□ Endress+Hauser (Shanghai) Instrumentation Co. Ltd.  
Tel. (021) 54 90 23 00, Fax (021) 54 90 23 03

### China – Beijing

□ Endress+Hauser (Beijing) Instrumentation Co. Ltd.  
Tel. (010) 65 88 24 68, Fax (010) 65 88 17 25

### Hong Kong – Tsimshatsui / Kowloon

□ Endress+Hauser (H.K.) Ltd.  
Tel. 8 52 25 28 31 20, Fax 8 52 28 65 41 71

### India – Mumbai

□ Endress+Hauser (India) Pvt. Ltd.  
Tel. (022) 56 93 83 33, Fax (022) 56 93 88 33 00

### Indonesia – Jakarta

PT Grama Bazita  
Tel. (21) 7 95 50 83, Fax (21) 7 97 50 89

### Iran – Tehran

Patsa Industry  
Tel. (021) 8 72 68 69, Fax (021) 8 71 96 66

### Israel – Netanya

Instrumetrics Industrial Control Ltd.  
Tel. (09) 8 35 70 90, Fax (09) 8 35 06 19

### Japan – Tokyo

□ Sakura Endress Co. Ltd.  
Tel. (0422) 54 06 11, Fax (0422) 55 02 75

### Jordan – Amman

A.P. Parpas Engineering S.A.  
Tel. (06) 5 53 92 83, Fax (06) 5 53 92 05

### Kazakhstan – Almaty

BEI Electro  
Tel. (72) 30 00 28, Fax (72) 50 71 30

### Korea, South – Seoul

□ Endress+Hauser (Korea) Co. Ltd.  
Tel. (02) 26 58 72 00, Fax (02) 26 59 28 38

### Kuwait – Safat

United Technical Services Est. For General Trading  
Tel. 2 41 12 63, Fax 2 41 15 93

### Lebanon – Jbeil Main Entry

Network Engineering  
Tel. (3) 94 40 80, Fax (9) 54 80 38

### Malaysia – Shah Alam, Selangor Darul Ehsan

□ Endress+Hauser (M) Sdn. Bhd.  
Tel. (03) 78 46 48 48, Fax (03) 78 46 88 00

### Pakistan – Karachi

Speedy Automation  
Tel. (021) 7 72 29 53, Fax (021) 7 73 68 84

### Philippines – Pasig City, Metro Manila

□ Endress+Hauser (Philippines) Inc.  
Tel. (2) 6 38 18 71, Fax (2) 6 38 80 42

### Saudi Arabia – Jeddah

Anasia Trading Est.  
Tel. (02) 6 53 36 61, Fax (02) 6 53 35 04

### Singapore – Singapore

□ Endress+Hauser (S.E.A.) Pte. Ltd.  
Tel. (65) 66 82 22, Fax (65) 66 68 48

### Sultanate of Oman – Ruwi

Mustafa & Sultan Science & Industry Co. L.L.C.  
Tel. 63 60 00, Fax 60 70 66

### Taiwan – Taipei

Kingjarl Corporation  
Tel. (02) 27 18 39 38, Fax (02) 27 13 41 90

### Thailand – Bangkok 10210

□ Endress+Hauser (Thailand) Ltd.  
Tel. (2) 9 96 78 11-20, Fax (2) 9 96 78 10

### United Arab Emirates – Dubai

Descon Trading L.L.C.  
Tel. (04) 2 65 36 51, Fax (04) 2 65 32 64

### Uzbekistan – Tashkent

Im Mexatronika-Tes  
Tel. (71) 1 91 77 07, Fax (71) 1 91 76 94

### Vietnam – Ho Chi Minh City

Tan Viet Bao Co. Ltd.  
Tel. (08) 8 33 52 25, Fax (08) 8 33 52 27

## Australia + New Zealand

### Australia – North Ryde NSW 2113

□ Endress+Hauser Australia Pty. Ltd.  
Tel. (02) 88 77 70 00, Fax (02) 88 77 70 99

### New Zealand – Auckland

EMC Industrial Group Ltd.  
Tel. (09) 4 15 51 10, Fax (09) 4 15 51 15

## All other countries

□ Endress+Hauser GmbH+Co. KG  
Instruments International  
Weil am Rhein, Germany  
Tel. (07621) 9 75 02, Fax (07621) 97 53 45

<http://www.endress.com>

□ Members of the Endress+Hauser group

05.03

Endress + Hauser

The Power of Know How

